

GRAFFE PER IMBALLAGGIO
CARTON CLOSING STAPLES

590

UTILIZZI
APPLICATIONS

Chiusura imballi di cartone,
fissaggio di cartone su bancale.

Carton closing, carton-to-skid.

SPECIFICHE
SPECIFICATIONS

Punti per barretta 58
Brads per strip 58

Finitura stanox
Finishing liquor finish

| Serie e identificazione (cod. serie) | modello | misure impiegabili (mm) | capacità caricatore (n.punti) | pressione (kg/cm ²) | peso (kg) | consumo aria (litri/colpo) | dimensioni (mm - L x W x H) |
|--------------------------------------|---------|-------------------------|-------------------------------|---------------------------------|--------------|--|-------------------------------|
| | model | applicable sizes (inch) | magazine capacity (pieces) | pressure (PSI) | weight (lbs) | air consumption (ft ³ /cycle) | dimensions (inch - L x W x H) |



PL 590.738

| 740 | PL 590.738 | 15 ÷ 38 9/16" ÷ 1-1/2" | 130 | 5 ÷ 7,5 70 ÷ 105 | 3,40 7,49 | 0,75 0,0264 | 345 x 77 x 345 13-9/16" x 3" x 13-9/16" |
|-----|------------|---------------------------|-----|---------------------|--------------|----------------|--|
|-----|------------|---------------------------|-----|---------------------|--------------|----------------|--|

0,85x1,80

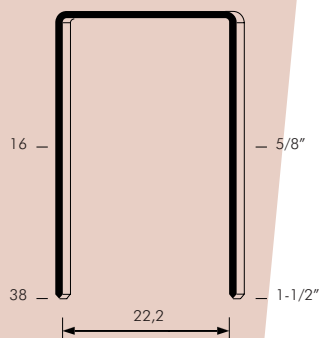

Gauge: 17

Crown: .941" (15/16")

GRAFFE PER IMBALLAGGIO
CARTON CLOSING STAPLES

590

UTILIZZI
APPLICATIONS

Chiusura imballi di cartone,
fissaggio di cartone su bancale.

Carton closing, carton-to-skid.

SPECIFICHE
SPECIFICATIONS

Punti per barretta 58
Brads per strip 58

Finitura stanox
Finishing liquor finish

| Serie e identificazione (cod. serie) | modello | misure impiegabili (mm) | capacità caricatore (n.punti) | pressione (kg/cm ²) | peso (kg) | consumo aria (litri/colpo) | dimensioni (mm - L x W x H) |
|--------------------------------------|---------|-------------------------|-------------------------------|---------------------------------|--------------|--|-------------------------------|
| | model | applicable sizes (inch) | magazine capacity (pieces) | pressure (PSI) | weight (lbs) | air consumption (ft ³ /cycle) | dimensions (inch - L x W x H) |



590.738

590.738 RF

| | | | | | | | |
|-----|-------------------|-----------------|-----|----------|------|--------|--------------------------|
| 740 | 590.738 | 15 ÷ 38 | 130 | 5 ÷ 7,5 | 2,00 | 0,75 | 345 x 77 x 243 |
| | | 9/16" ÷ 1-1/2" | 130 | 70 ÷ 105 | 4,40 | 0,0264 | 13-9/16" x 3" x 9-9/16" |
| | 590.738 RF | 18 ÷ 38 | 130 | 5 ÷ 7,5 | 2,70 | 0,75 | 345 x 77 x 258 |
| | | 11/16" ÷ 1-1/2" | 130 | 70 ÷ 105 | 5,95 | 0,0264 | 13-9/16" x 3" x 10-3/16" |



Versione RF - RF model

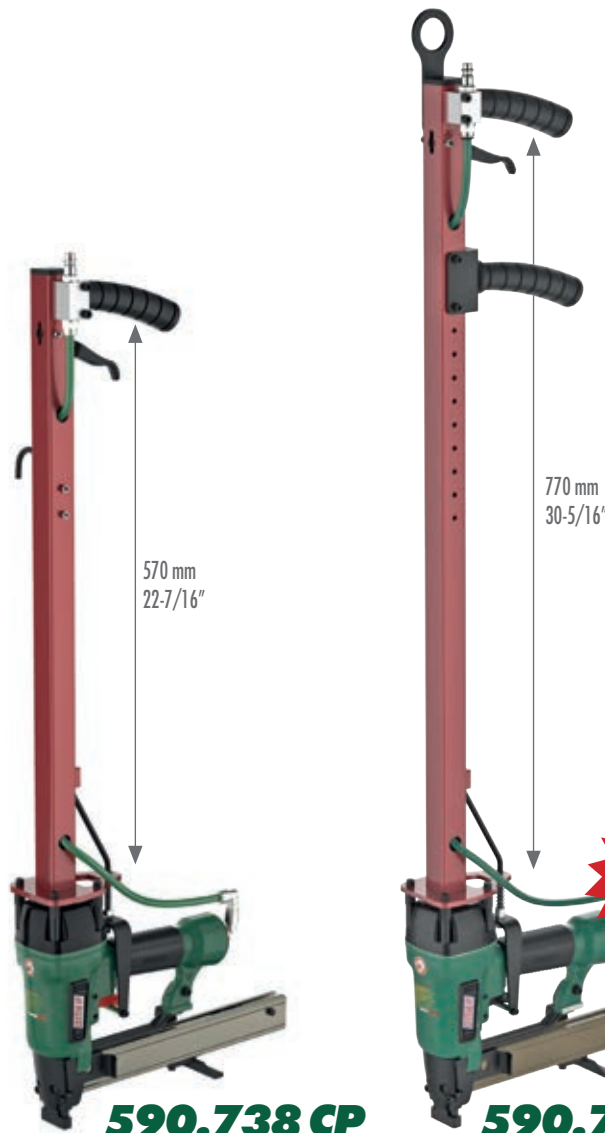

590.738 CP

590.738 CPI



Versione CP - CP model

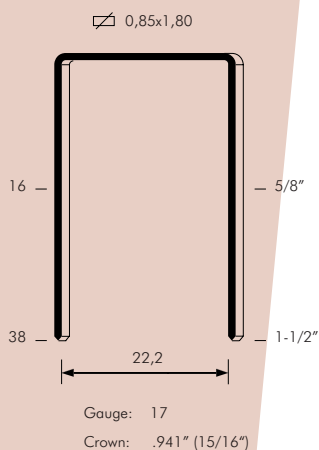

| | | | | | | | |
|-----|--------------------|----------------|-----|----------|------|--------|-------------------------------|
| 740 | 590.738 CP | 15 ÷ 38 | 130 | 5 ÷ 7,5 | 4,06 | 0,75 | 345 x 77 x 870 |
| | | 9/16" ÷ 1-1/2" | 130 | 70 ÷ 105 | 8,95 | 0,0264 | 13-9/16" x 3" x 34-1/4" |
| | 590.738 CPI | 15 ÷ 38 | 130 | 5 ÷ 7,5 | 4,50 | 0,75 | 345 x 104 x 1120 |
| | | 9/16" ÷ 1-1/2" | 130 | 70 ÷ 105 | 9,92 | 0,0264 | 13-9/16" x 4-1/16" x 44-1/16" |