

CHIODI ROTOLO ELETTR. 16°
WIRE COIL NAILS 16°

modello	diametro gambo (mm)	misure impieghi (mm)	capacità caricatore (n.punti)	pressione (kg/cm ²)	peso (kg)	consumo aria (litri/colpo)	dimensioni (mm - L x W x H)
model	shank diameter (inch)	applicable sizes (inch)	magazine capacity (pieces)	pressure (PSI)	weight (lb)	air consumption (l/cycle)	dimensions (inch - L x W x H)

CNW 23

UTILIZZI APPLICATIONS

Rivestimenti, pavimentazioni, pedane, recinzioni, tetti in legno, finiture esterne in legno, imballaggi in legno.

Sheathing, subflooring, decking, fencing, roof decking, exterior trimming, wooden packaging.

SPECIFICHE SPECIFICATIONS

Punti per rotolo 300
Nails per coil 300

Finitura lucido
Finishing bright

A richiesta zincato, inox,
On request galvanized,
stainless steel,
jumbo coil

Gambo a richiesta
Shank on request



Ø 5,4 ÷ Ø 5,9
Head dia: .212" ÷ .232"

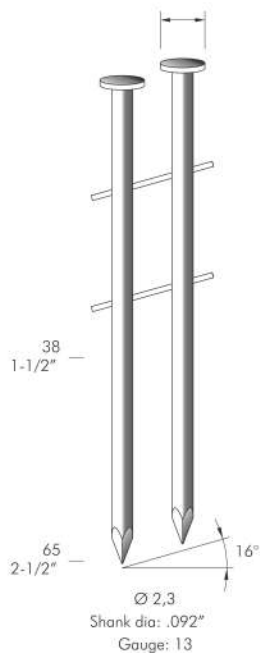

Avvolgimento piatto
Flat winding



CN23.57

MORE	CN23.57	2,1 ÷ 2,3 .082" ÷ .092"	25 ÷ 57 1" ÷ 2-1/4"	300 300	5 ÷ 8 70 ÷ 115	2,67 5,89	1,70 0,06003	310 x 132 x 285 12-3/16" x 5-3/16" x 11-1/4"
------	---------	----------------------------	------------------------	------------	-------------------	--------------	-----------------	---



CN25.65

MORE	CN25.65	2,1 ÷ 2,5 .082" ÷ .099"	38 ÷ 65 1-1/2" ÷ 2-1/2"	300 300	5 ÷ 8 70 ÷ 115	2,75 6,06	1,90 0,6709	300 x 130 x 312 11-7/8" x 5-1/8" x 12-1/4"
------	---------	----------------------------	----------------------------	------------	-------------------	--------------	----------------	---



CN28.65

MORE	CN28.65	2,3 ÷ 2,5 .092" ÷ .099"	32 ÷ 65 1-1/4" ÷ 2-1/2"	300 300	5 ÷ 8 70 ÷ 115	2,05 4,50	2,97 0,10488	310 x 128 x 326 12-3/16" x 5-1/16" x 12-7/8"
------	---------	----------------------------	----------------------------	------------	-------------------	--------------	-----------------	---