

modello	diámetro gambo (mm)	misure impiegabili (mm)	capacità caricatore (n.punti)	pressione (kg/cm <sup>2</sup> )	peso (kg)	consumo aria (litri/colpo)	dimensioni (mm - L x W x H)
model	shank diameter (inch)	applicable sizes (inch)	magazine capacity (pieces)	pressure (PSI)	weight (lbs)	air consumption (lit/cycle)	dimensions (inch - L x W x H)

CHIODI ROTOLO ELETTR. 16°  
WIRE COIL NAILS 16°

# CNW 31



**CN33.83**

MORE	CN33.83	2,5 ÷ 3,3	50 ÷ 83	225	5 ÷ 8	3,90	3,68	350 x 132 x 364
		.099" ÷ .131"	2" ÷ 3-1/4"	225	70 ÷ 115	8,60	0,12996	13-3/4" x 5-3/16" x 14-5/16"



**CN33.90**

MORE	CN33.90	2,5 ÷ 3,3	45 ÷ 90	225	5 ÷ 8	3,50	2,97	388 x 145 x 370
		.099" ÷ .131"	1-3/4" ÷ 3-5/8"	225	70 ÷ 115	7,70	0,10488	15-1/4" x 5-1/2" x 14-9/16"



**CN38.100**



**CN38.130**

MORE	CN38.100	2,8 ÷ 3,8	57 ÷ 100	225	5 ÷ 8	5,25	3,30	338 x 153 x 418
		.110" ÷ .150"	2-1/4" ÷ 4"	225	70 ÷ 115	11,57	0,11654	13-5/16" x 6" x 16-1/2"
	CN38.130	3,1 ÷ 3,8	75 ÷ 130	225	5 ÷ 8	5,80	3,80	338 x 153 x 479
		.122" ÷ .150"	3" ÷ 5"	225	70 ÷ 115	12,80	0,13419	13-5/16" x 6" x 18-7/8"

## UTILIZZI APPLICATIONS

Rivestimenti, recinzioni in legno, casse in legno, imballaggi in legno, bancali, tetti e case in legno.  
Sheathing, fencing, case and box assembly, wooden packaging, pallets, wooden roof and house.

## SPECIFICHE SPECIFICATIONS

Punti per rotolo 225  
Nails per coil 225

Finitura lucido  
Finishing bright

A richiesta zincato, inox, bobina jumbo  
On request galvanized, stainless steel, jumbo coil

Gambo a richiesta Shank on request



Ø 6,9  
Head dia: .272"

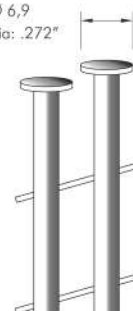

80  
3-1/8"

Ø 3,1  
Shank dia: .120"  
Gauge: 11

100  
4"

16°

Avvolgimento piatto  
Flat winding

