

CHIODI ROTOLO ELETTR. 16°
WIRE COIL NAILS 16°

modello	diametro gambo (mm)	misure impieghiabili (mm)	capacità caricatore (n.punti)	pressione (kg/cm ²)	peso (kg)	consumo aria (litri/colpo)	dimensioni (mm - L x W x H)
model	shank diameter (inch)	applicable sizes (inch)	magazine capacity (pieces)	pressure (PSI)	weight (lb)	air consumption (lit/cycle)	dimensions (inch - L x W x H)

CNW 34

UTILIZZI APPLICATIONS

Rivestimenti, recinzioni in legno, casse in legno, imballaggi in legno, bancali, tetti e case in legno.
 Sheathing, fencing, case and box assembly, wooden packaging, pallets, wooden roof and house.

SPECIFICHE SPECIFICATIONS

Punti per rotolo 150
 Nails per coil 150

Finitura lucido
 Finishing bright

A richiesta zincato
 On request galvanized

Gambo a richiesta Shank on request



CN38.100

MORE	CN38.100	2,8 + 3,8 .110" + .150"	57 + 100 2-1/4" + 4"	150 150	5 + 8 70 + 115	5,25 11,57	3,30 0,11654	338 x 153 x 418 13-5/16" x 6" x 16-1/2"
------	----------	----------------------------	-------------------------	------------	-------------------	---------------	-----------------	--

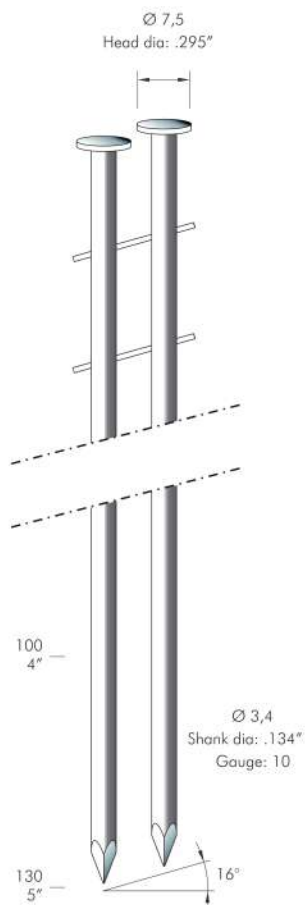

Avvolgimento piatto
 Flat winding



CN38.130

MORE	CN38.130	3,1 + 3,8 .122" + .150"	75 + 130 3" + 5"	150 150	5 + 8 70 + 115	5,80 12,80	3,80 0,13419	338 x 153 x 479 13-5/16" x 6" x 18-7/8"
------	----------	----------------------------	---------------------	------------	-------------------	---------------	-----------------	--