

CHIODI ROTOLO ELETTR. 16°
WIRE COIL NAILS 16°

CNW 38

UTILIZZI APPLICATIONS

Rivestimenti, recinzioni in legno, imballaggi in legno, bancali, costruzione casse in legno, tetti e case in legno.

Sheathing, fencing, wooden packaging, pallets, case and box assembly, wooden roof and house.

SPECIFICHE SPECIFICATIONS

Punti per rotolo 125
 Nails per coil 125

Finitura lucido
 Finishing bright

A richiesta zincato
 On request galvanized

Gambo a richiesta Shank on request

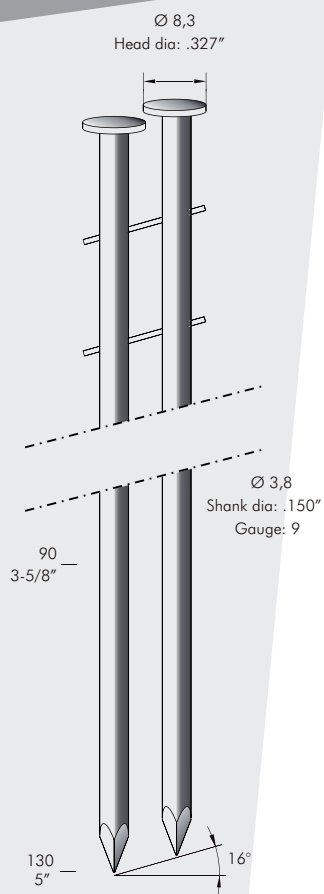
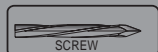

Avvolgimento piatto
 Flat winding



serie cilindrica 100 series	modello	diametro gambo (mm)	misure impieghiabili (mm)	capacità caricatore (n.punti)	pressione (kg/cm ²)	peso (kg)	consumo aria (litri/colpo)	dimensioni (mm - L x W x H)
	model	shank diameter (inch)	applicable sizes (inch)	magazine capacity (pieces)	pressure (PSI)	weight (lbs)	air consumption (ft ³ /cycle)	dimensions (inch - L x W x H)



CN38.100

MORE	CN38.100	2,8 ÷ 3,8	57 ÷ 100	125	5 ÷ 8	5,25	3,30	338 x 153 x 418
		.110" ÷ .150"	2-1/4" ÷ 4"	125	70 ÷ 115	11,57	0,11654	13-5/16" x 6" x 16-1/2"



CN38.130

MORE	CN38.130	3,1 ÷ 3,8	75 ÷ 130	125	5 ÷ 8	5,80	3,80	338 x 153 x 479
		.122" ÷ .150"	3" ÷ 5"	125	70 ÷ 115	12,80	0,13419	13-5/16" x 6" x 18-7/8"