

**Azionamento singolo con doppia attivazione**

Single actuation with dual activation

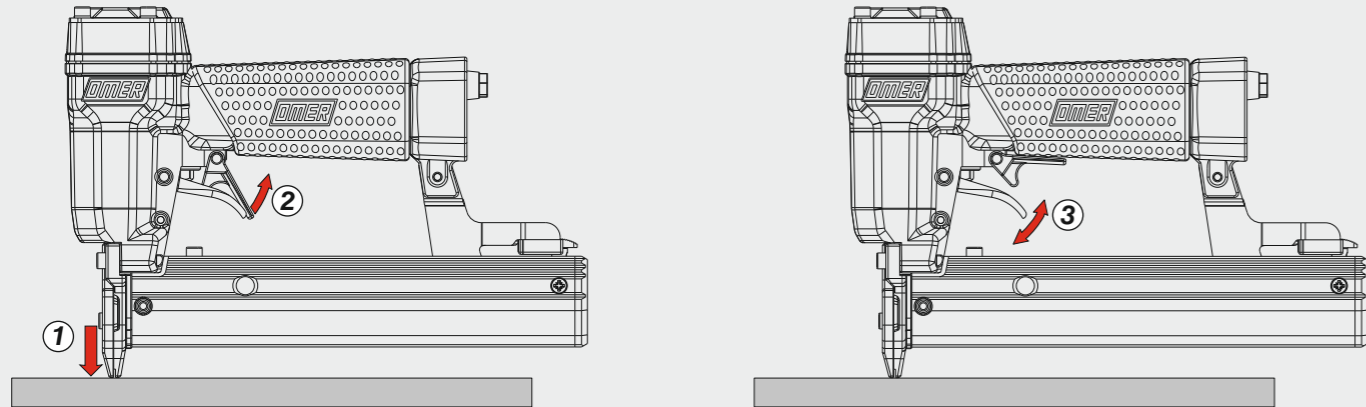

Caricamento - Loading - Laden - Chargement - Carga - Γέμισμα - Carregamento - Laden - Yükleme - Laddning - Plnění - Plnenie

**Caricamento da sopra**

Top load magazine

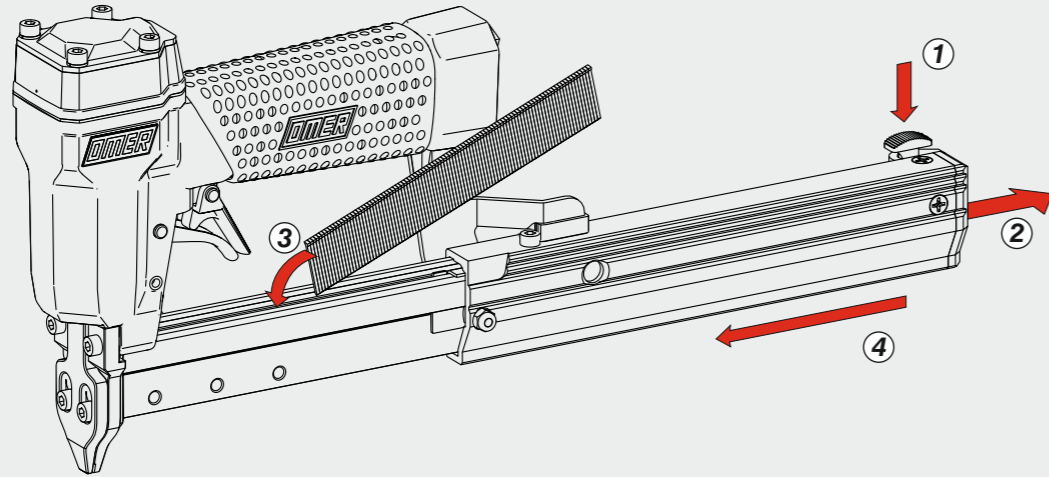

Caratteristiche - Features - Merkmale - Caractéristiques - Características  
 Χαρακτηριστικά - Características - Kenmerken - Özellikler - Funktionen - Vlastnosti - Vlastnosti

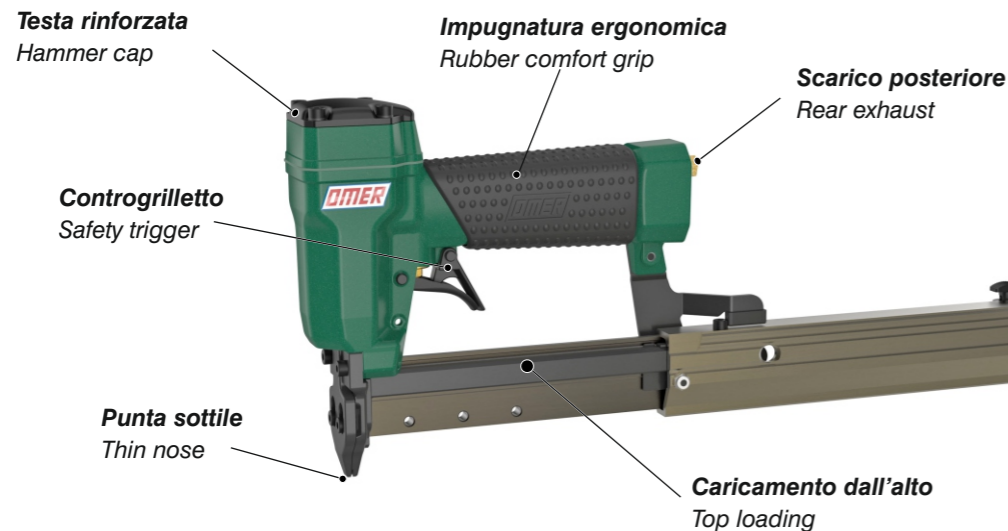

<b>Manuale d'uso, manutenzione e parti di ricambio</b>	<b>Parte 2</b>
<b>Manual for use, maintenance and spare parts</b>	<b>Part 2</b>
<b>Bedienungs- und Wartungshandbuch sowie Ersatzteilliste</b>	<b>Teil 2</b>
<b>Mode d'emploi, de maintenance et pièces de rechange</b>	<b>Partie 2</b>
<b>Manual de uso, mantenimiento y recambios</b>	<b>Part 2</b>
<b>Εγχειρίδιο χρήσης, συντήρησης και ανταλλακτικών</b>	<b>Μέρος 2</b>
<b>Manual de uso, manutenção e peças sobresselentes</b>	<b>Parte 2</b>
<b>Handleiding voor gebruik, onderhoud en wisselstukken</b>	<b>Deel 2</b>
<b>Kullanım, bakım ve yedek parça kılavuzu</b>	<b>Kisim 2</b>
<b>Användar-, underhålls- och reservdelshandbok</b>	<b>Del 2</b>
<b>Návod k používání a údržbě a náhradní díly</b>	<b>Část 2</b>
<b>Návod na obsluhu, údržbu a náhradné diely</b>	<b>Časť 2</b>



**12P.25 H**

cod. 11412290H



Dati tecnici Technical data Technische Daten Tehniska data	Caractéristiques techniques Datos técnicos Τεχνικά χαρακτηριστικά Technické údaje	Dados técnicos Technische gegevens Teknik veriler Technické údaje		
<b>Misure impiegabili</b> Lengths Verwendbare Nagellänge Dimensioner som kan användas	Dimensions utiles Medidas de longitud Μήκος Αναλωσίμου Příпустné rozměry	Medidas utilizáveis Toepasbare afmetingen Boy Použitelné rozmery	mm inch	<b>10÷28</b> <b>3/8"÷ 1-1/8"</b>
<b>Capacità caricatore n° punti</b> Magazine capacity Magazinkapazität Nägel Magasinkapacitet Antal punkter	Capacité chargeur n° de points Capacidad cargador n° puntos Δυνατότητα γεμιστερα Kapacita zásobníku p. sponek	Capacidade carregador n° pontos Capaciteit magazijn in aantal spijkers Dergi kapasitesi Kapacita zásobníka p. spôn		<b>100</b>
<b>Pressione d'esercizio</b> Operating pressure Betriebsdruck Drifttryck	Pression d'exercice Presión de servicio Πίεση λειτουργίας Pracovní tlak	Pressão de serviço Werkdruk Çalışma basıncı Prevádzkový tlak	bar psi	<b>4,5÷6</b> <b>65÷90</b>
<b>Consumo aria</b> Air consumption Luftverbrauch Luftförbrukning	Consommation d'air Consumo aire Κατανάλωση αέρα Spotreba vzduchu	Consumo ar Luchtverbruik Hava tüketimi Spotreba vzduchu	lt/colpo ft <sup>3</sup> /cycle	<b>0,15</b> <b>0,0053</b>
<b>Peso</b> Weight Gewicht Vikt	Poids Peso Βάρος Hmotnost	Peso Gewicht Ağırlık Hmotnost	kg lbs	<b>1,04</b> <b>2,29</b>
<b>Dimensioni</b> Dimensions Abmessungen Dimensioner (AxBxH)	Dimensions Dimensiones Διαστάσεις Rozměry	Dimensões Afmetingen Boyutlar Rozmery	mm inch	<b>230x43x166</b> <b>9-1/16"x1-11/16"x6-9/16"</b> (LxWxH)
<b>EN 12549 :2009 EN ISO 4871 :2009</b>				
<b>Pressione sonora in pos. operatore</b> Sound pressure in operator's position Schalldruck am Arbeitsplatz Ljudtryck på operatörsplatsen	Pression sonore poste Opérateur Presión sonora en la pos. del operador Ηχητική πίεση στη θέση του χειριστή Akustický tlak v místě obsluhy	Pressão sonora na posição Operador Geluidsdruk op de werkplaats Operatör pozisyonunda ses basıncı Akustický tlak v mieste obsluhy	dB(A)	<b>80</b> (K= 4 dB)
<b>EN 12549 :2009 EN ISO 3746 :2011 EN ISO 4871 :2009</b>				
<b>Potenza sonora emessa</b> Sound power emitted Emitierte Schalleistung Avgiven ljudeffekt	Puissance sonore émise Potencia sonora emitida Εκπεμπόμενη ηχητική ισχύς Emitovaný akustický tlak	Potência sonora emitida Geëmitteerd geluidsvermogen Çıkan ses gücü (ses desibeli) Výstupný akustický výkon	dB(A)	<b>86</b> (K= 4 dB)
<b>CEN ISO/TS 8662-11 :2006 EN ISO 5349-2 :2004 EN 12096 :1999</b>				
<b>Emissione vibratoria sull'impugnatura</b> Vibratory emissions on handle Vibrationsemission am Griff Vibrationsemission på handtaget	Émission vibratoire sur la prise en main Emisión de vibraciones en la empuñadura Εκπεμπόμενες δονήσεις στη λαβή Emise vibrací na rukojet	Emissão vibratória na empunhadura Trillingsemissie op de handgreep Tutamak üzerinde vibrasyon emisyonları Emisie vibrácií na rukoväti	m/s <sup>2</sup>	<b>&lt;2,5</b> (K= 2 m/s <sup>2</sup> )

**Tipo di punto**  
Type of fastener  
Befestigungsmittel  
Type de rivet  
Tipo de punto  
Τύπος αναλωσίμου  
Tipo de agrafó  
Type nietjes  
Zimba ve çivi tipleri  
Typ av stygn  
Typ sponky  
Typ spony

**Brads 12P**

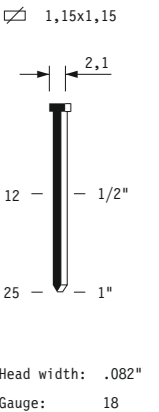

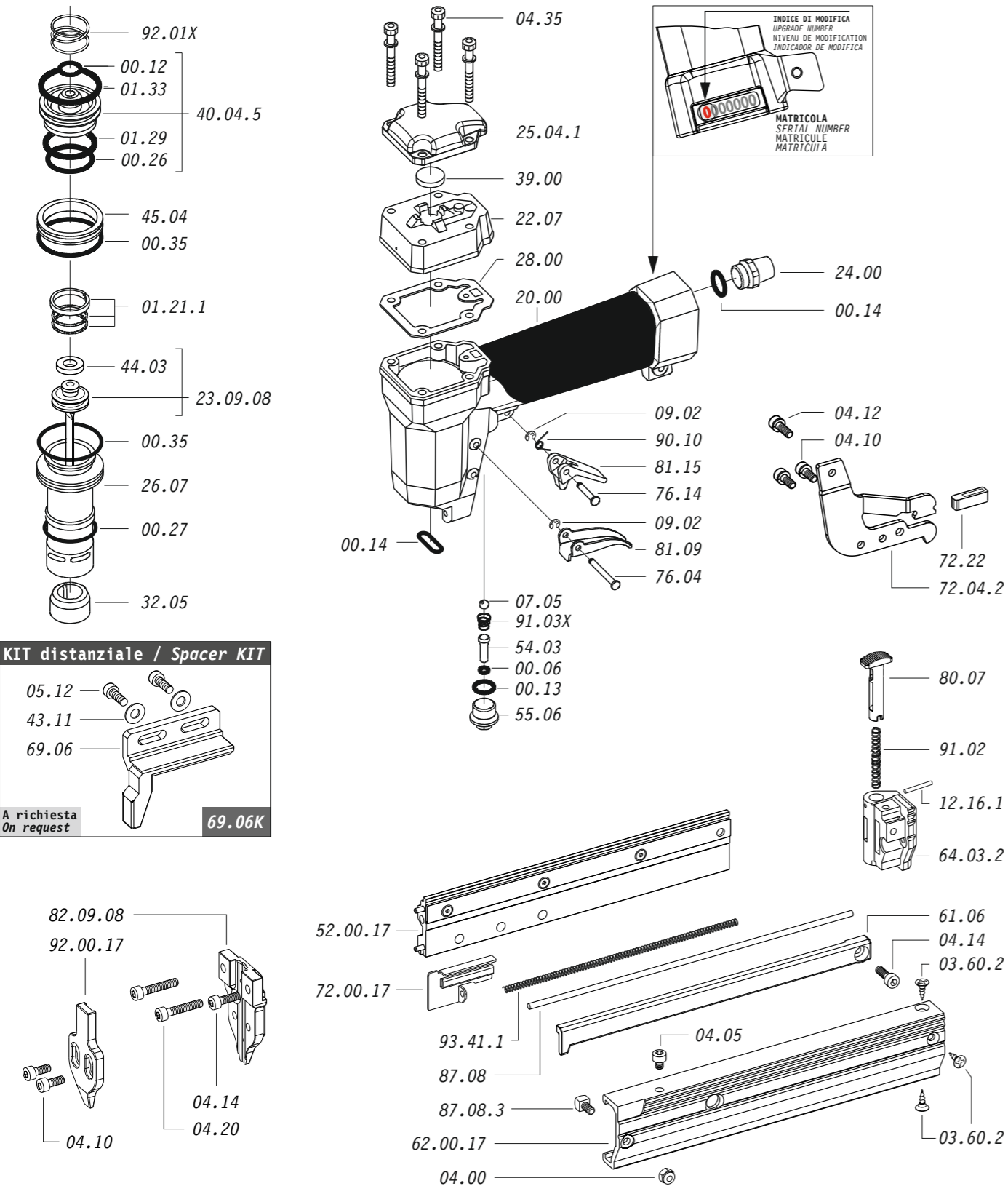

Dotazioni - Equipment - Ausstattung - Outillage - Dotaciones - Εξοπλισμός  
Dotações - Uitrusting - Donanımlar - Utrustning - Vybavení - Vybava



07.30

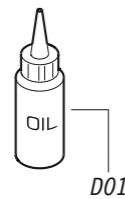

D01

**12P.25 H**

cod. 11412290H

Cod.	Descrizione	Description
00.06	O-Ring	O-Ring
00.12	O-Ring	O-Ring
00.13	O-Ring	O-Ring
00.14	O-Ring	O-Ring
00.26	O-Ring	O-Ring
00.27	O-Ring	O-Ring
00.35	O-Ring	O-Ring
01.21.1	Guarnizione	Gasket
01.29	O-Ring	O-Ring
01.33	O-Ring	O-Ring
03.60.2	Vite	Screw
04.00	Dado	Nut
04.05	Vite	Screw
04.10	Vite	Screw
04.12	Vite	Screw
04.14	Vite	Screw
04.20	Vite	Screw
04.35	Vite	Screw
05.12	Vite	Screw
07.05	Sfera	Ball
07.30	Chiave esagonale	Hex. bar wrench
09.02	Anello elastico	Elastic ring
12.16.1	Spina	Pin
20.00	Corpo	Body
22.07	Testa	Head
24.00	Silenziatore	Silencer
25.04.1	Deflettore	Deflector
26.07	Cilindro	Cylinder
28.00	Guarnizione	Gasket
32.05	Ammortizzatore	Bumper
39.00	Guarnizione scarico	Exhaust gasket
40.04.5	Valvola completa	Valve ass'y
43.11	Rondella	Washer
44.03	Ammortizzatore	Bumper
45.04	Anello valvola	Ring
54.03	Pulsante sparo	Trigger valve
55.06	Raccordo	Bush
61.06	Guida Dx	Right Guide
64.03.2	Fondello	Cap
69.06	Distanziale	Spacer
69.06K	KIT Distanziale	Spacer KIT
72.04.2	Reggicaricatore	Support
72.22	Fermo carrello	Slider-stop
76.04	Perno	Pin
76.14	Perno	Pin
80.07	Grilletto chiusura	Trigger lock
81.09	Grilletto comando	Trigger
81.15	Controgrilletto	Safety
87.08	Portamolla	Spring bearing
87.08.3	Supporto	Support
90.10	Molla	Spring
91.02	Molla	Spring
91.03X	Molla	Spring
92.01X	Molla	Spring
93.41.1	Molla	Spring
23.09.08	Battente	Driver
52.00.17	Caricatore	Magazine
62.00.17	Carrello	Slider
72.00.17	Spingipunto	Pusher
82.09.08	Controtestina	Nose
92.00.17	Testina	Nose plate
D01	Bocchetta olio	Oiler

Guarnizioni - O-Rings - Dichtungen - Joints toriques - Junta - Δακτύλιος στεγανοποίησης  
Vedantes - O-ringen - Contalar - O-ringar - Těsnění - Tesnenia

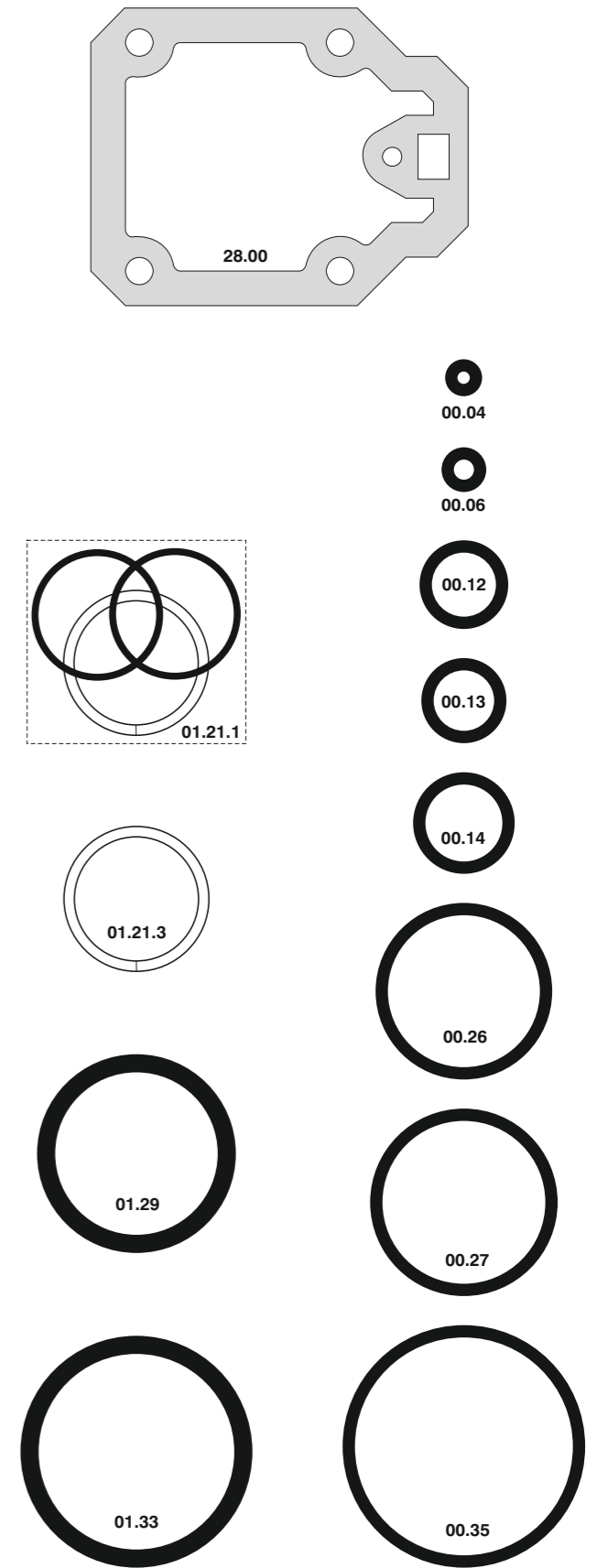

00.70.5

**12P.25 H**

cod. 11412290H

Indice di modifica  
Upgrade number

4

Disincemento - Jam clearing - Staubeseitigung - Décoincement - Desatascamiento - Απεμπλοκή  
Desencravamento - Deblokkering bij vastlopen - Sıkışma giderme - Rensning av igensättningar - Uvolnění - Uvolnění

