

## Collegamento - Connection

**Collegamento:**  
Connection:

**Valvola 3/2 NC**  
Valve 3/2 NC

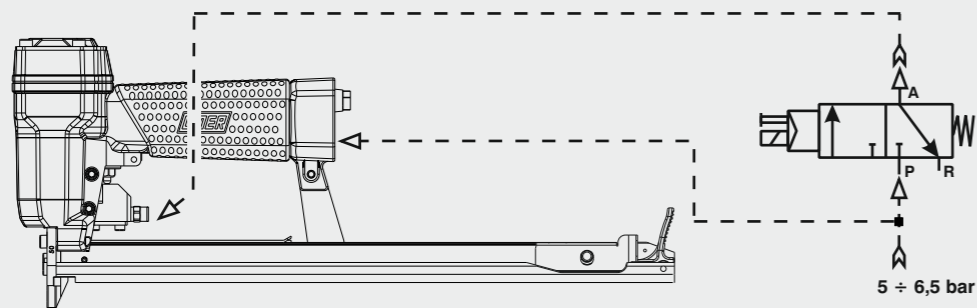

Caricamento - Loading - Laden - Chargement - Carga - Γέμισμα - Carregamento - Laden - Yükleme - Laddning - Plnění - Plnenie

**Caricamento da sopra**  
Top load magazine

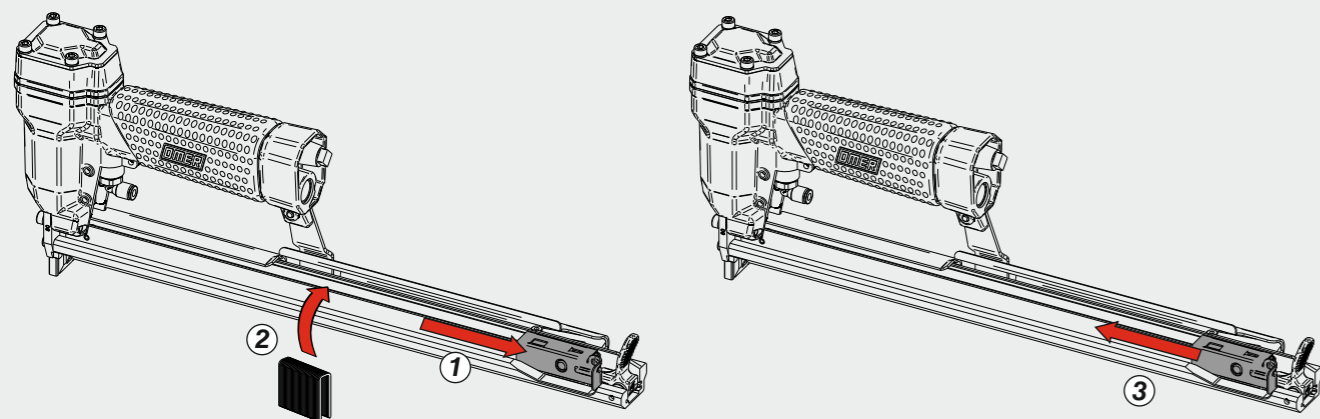

**Disincippamento - Jam clearing - Staubeseitigung - Décoincement - Desatascamiento - Απεμπλοκή**  
Desencravamento - Deblokkering bij vastlopen - Sıkışma giderme - Rensning av igensättningar - Uvolnění - Uvolnenie

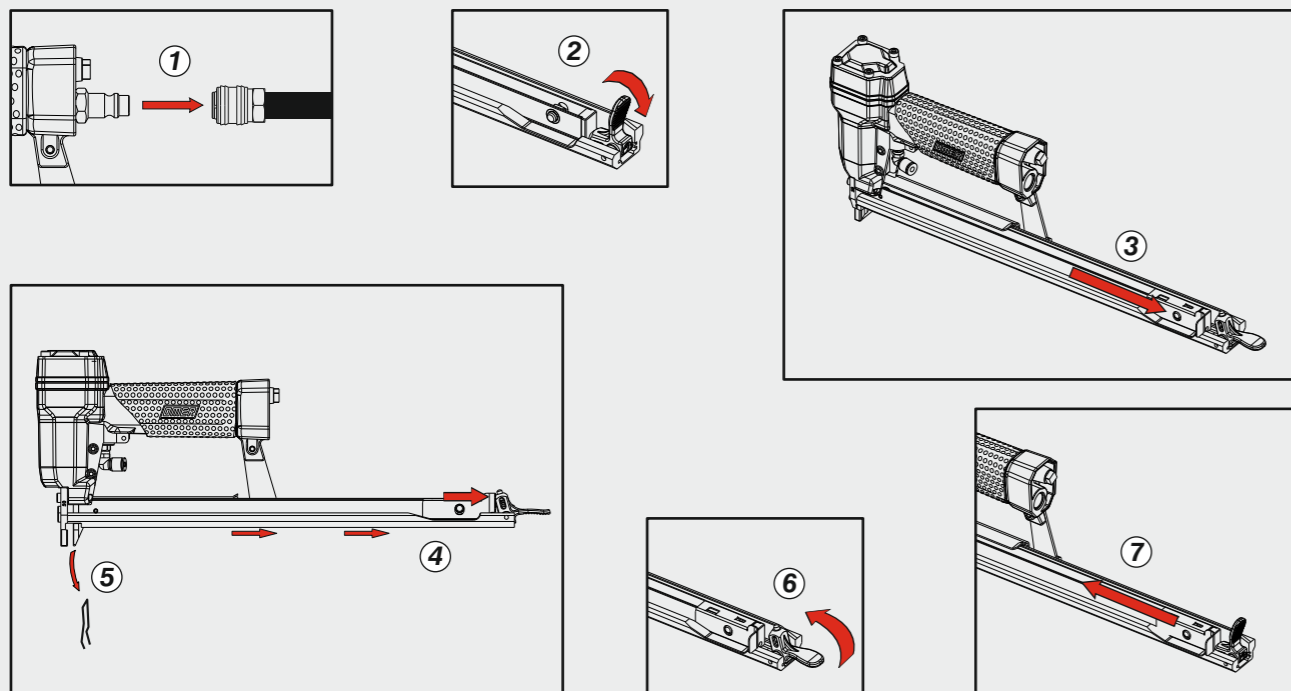

# OMER®

**Manuale d'uso, manutenzione e parti di ricambio**  
**Manual for use, maintenance and spare parts**  
**Bedienungs- und Wartungshandbuch sowie Ersatzteilleiste**  
**Mode d'emploi, de maintenance et pièces de rechange**  
**Manual de uso, mantenimiento y recambios**  
**Εγχειρίδιο χρήσης, συντήρησης και ανταλλακτικών**  
**Manual de uso, manutenção e peças sobresselentes**  
**Handleiding voor gebruik, onderhoud en wisselstukken**  
**Kullanım, bakım ve yedek parça kılavuzu**  
**Användar-, underhålls- och reservdelshandbok**  
**Návod k používání a údržbě a náhradní díly**  
**Návod na obsluhu, údržbu a náhradné diely**

**Parte 2**  
**Part 2**  
**Teil 2**  
**Partie 2**  
**Part 2**  
**Μέρος 2**  
**Parte 2**  
**Deel 2**  
**Kisim 2**  
**Del 2**  
**Část 2**  
**Čast 2**



## 50.16 CLT-3

cod. 11567540-3



### Dati tecnici

Technical data  
Technische Daten  
Tehniska data

### Caractéristiques techniques

Datos técnicos  
Τεχνικά χαρακτηριστικά  
Technické údaje

### Dados técnicos

Technische gegevens  
Teknik veriler  
Technické údaje

### Misure impiegabili

Lengths  
Verwendbare Nagellänge  
Dimensioner som kan användas

### Dimensions utiles

Medidas de longitud  
Μήκος Αναλωσίμου  
Příпустné rozměry

### Medidas utilizáveis

Toepasbare afmetingen  
Boy  
Použitelné rozmery

**mm** **4 ÷ 16**  
**inch** **5/32" ÷ 5/8"**

### Capacità caricatore n° punti

Magazine capacity  
Magazinkapazität Nägel  
Magasinkapacitet Antal punkter

### Capacité chargeur n° de points

Capacidad cargador n° puntos  
Δυνατότητα γεμιστερα  
Kapacita zásobníku p. sponek

### Capacidade carregador n° pontos

Capaciteit magazijn in aantal spijkers  
Dergi kapasitesi  
Kapacita zásobníka p. spôn

**210**

### Pressione d'esercizio

Operating pressure  
Betriebsdruck  
Drifttryck

### Pression d'exercice

Presión de servicio  
Πίεση λειτουργίας  
Pracovní tlak

### Pressão de serviço

Werkdruk  
Çalışma basıncı  
Prevádzkový tlak

**bar** **4 ÷ 6**  
**psi** **60 ÷ 90**

### Consumo aria

Air consumption  
Luftverbrauch  
Luftförbrukning

### Consommation d'air

Consumo aire  
Κατανάλωση αέρα  
Spotreba vzduchu

### Consumo ar

Luchtverbruik  
Hava tüketimi  
Spotreba vzduchu

**lt/colpo** **0,13**  
**ft<sup>3</sup>/cycle** **0,00459**

### Peso

Weight  
Gewicht  
Vikt

### Poids

Peso  
Βάρος  
Hmotnost

### Peso

Gewicht  
Ağırlık  
Hmotnost

**kg** **1,17**  
**lbs** **2,57**

### Dimensioni

Dimensions  
Abmessungen  
Dimensioner (AxBxH)

### Dimensions

Dimensiones  
Διαστάσεις  
Rozměry

### Dimensões

Afmetingen  
Boyutlar  
Rozmery

**mm** **378x43x148**  
**inch** **14-7/8"x1-11/16"x5-7/8"**

(LxWxH)

**EN 12549 :2009 EN ISO 3746 :2011 EN ISO 4871 :2009**

### Potenza sonora emessa

Sound power emitted  
Emitierte Schalleistung  
Avgiven ljudeffekt

### Puissance sonore émise

Potencia sonora emitida  
Εκτεμπόμενη ηχητική ισχύς  
Emitovaný akustický tlak

### Potência sonora emitida

Geëmitteerd geluidsvermogen  
Çıkan ses gücü (ses desibeli)  
Výstupný akustický výkon

**dB(A)** **87**

(K = 4 dB)

**Tipo di punto**  
Type of fastener  
Befestigungsmittel  
Type de rivet  
Tipo de punto  
Τύπος αναλωσίμου  
Tipo de agrafe  
Type nietjes  
Zimba ve çivi tipleri  
Typ av stygn  
Typ sponky  
Typ spony

**50**

0,50x1,25

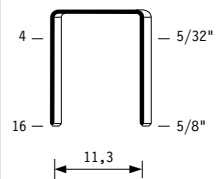

Crown: .484" (1/2")  
Gauge: 20

11567540-3\_5016CLT-3\_5\_rev22\_03/02/2026 MH

**DO NOT  
HANDHELD  
THIS TOOL**



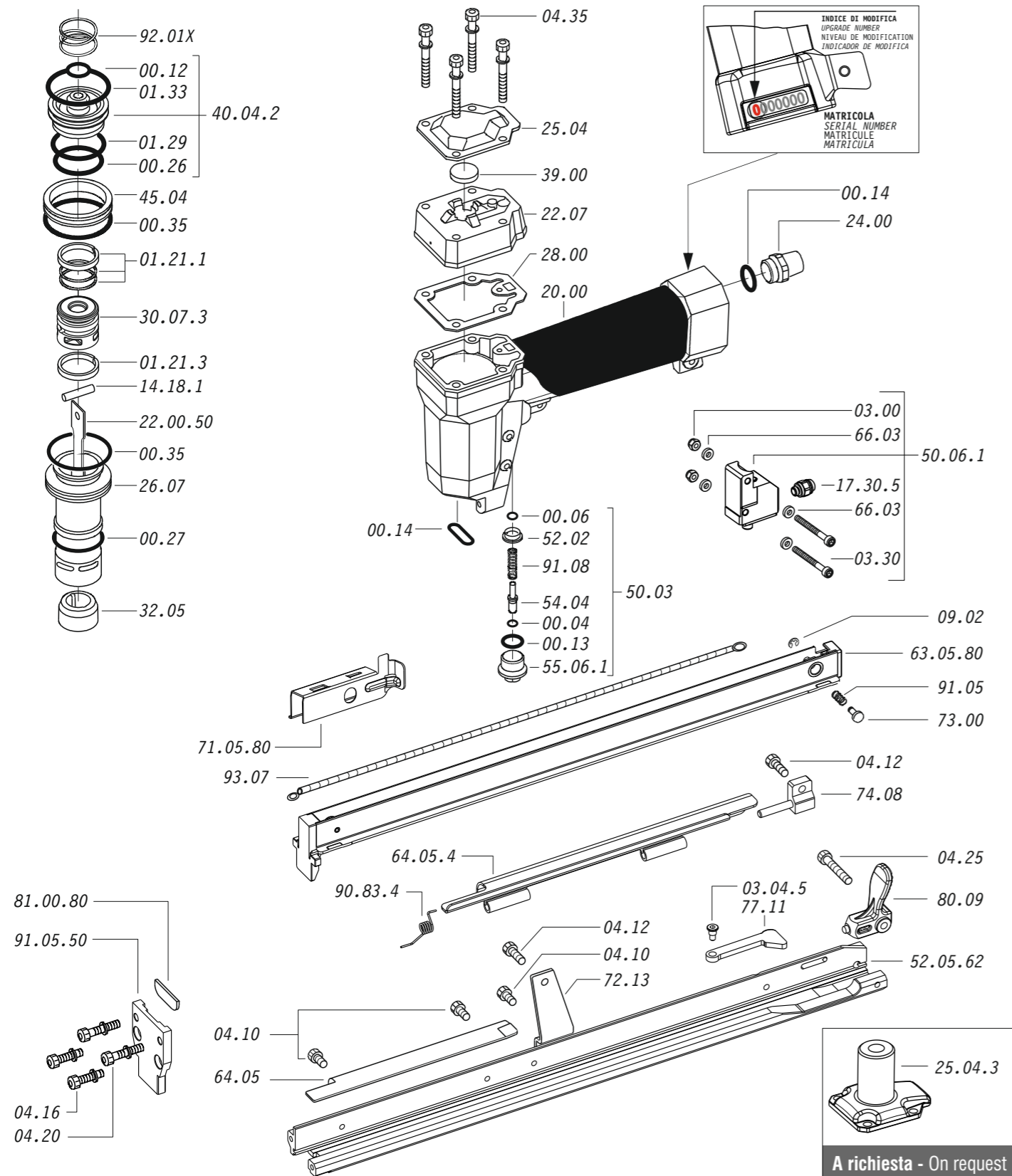

Dotazioni - Equipment - Ausstattung - Outillage - Dotaciones - Εξοπλισμός  
Dotações - Uitrusting - Donanımlar - Utrustning - Vybavení - Vybava



07.25



07.30



D01

**50.16 CLT-3**

cod. 11567540-3

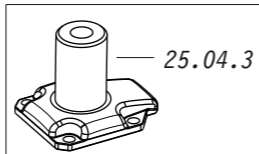

A richiesta - On request

Cod.	Descrizione	Description
00.04	O-Ring	O-Ring
00.06	O-Ring	O-Ring
00.12	O-Ring	O-Ring
00.13	O-Ring	O-Ring
00.14	O-Ring	O-Ring
00.26	O-Ring	O-Ring
00.27	O-Ring	O-Ring
00.35	O-Ring	O-Ring
01.21.1	Guarnizione	Gasket
01.21.3	Guarnizione	Gasket
01.29	O-Ring	O-Ring
01.33	O-Ring	O-Ring
03.00	Dado	Nut
03.04.5	Vite	Screw
03.30	Vite	Screw
04.10	Vite	Screw
04.12	Vite	Screw
04.16	Vite	Screw
04.20	Vite	Screw
04.25	Vite	Screw
04.35	Vite	Screw
07.25	Chiave esagonale	Hex. bar wrench
07.30	Chiave esagonale	Hex. bar wrench
09.02	Anello elastico	Elastic ring
14.18.1	Spina	Pin
17.30.5	Attacco	Connection
20.00	Corpo	Body
22.07	Testa	Head
24.00	Silenziatore	Silencer
25.04	Deflettore	Exhaust deflector
25.04.3	Supporto	Support
26.07	Cilindro	Cylinder
28.00	Guarnizione	Gasket
30.07.3	Pistone	Piston
32.05	Ammortizzatore	Bumper
39.00	Guarnizione scarico	Exhaust gasket
40.04.2	Valvola completa	Valve ass'y
45.04	Anello valvola	Ring
50.03	Pulsante completo	Valve ass'y
50.06.1	Comando a distanza	Remote control trigger
52.02	Boccola	Bush
54.04	Pulsante	Trigger valve
55.06.1	Raccordo	Bush
64.05	Carter	Hold down
64.05.4	Carter mobile	Hold down
66.03	Rondella	Washer
72.13	Reggicaricatore	Support
73.00	Perno	Pin
74.08	Staffa	Support
77.11	Leva	Lever
80.09	Grilletto chiusura	Trigger
90.83.4	Molla	Spring
91.05	Molla	Spring
91.08	Molla	Spring
92.01X	Molla	Spring
93.07	Molla	Spring
22.00.50	Battente	Driver
52.05.62	Caricatore	Magazine
63.05.80	Carrello	Slider
71.05.80	Spingipunto	Pusher
81.00.80	Controtestina	Nose
91.05.50	Testina	Nose plate
D01	Bocchetta olio	Oiler

Guarnizioni - O-Rings - Dichtungen - Juntas - Διακόλιος στεγανοποίησης  
Vedantes - O-ringen - Contalar - O-ringar - Tésnéni - Tesnenia

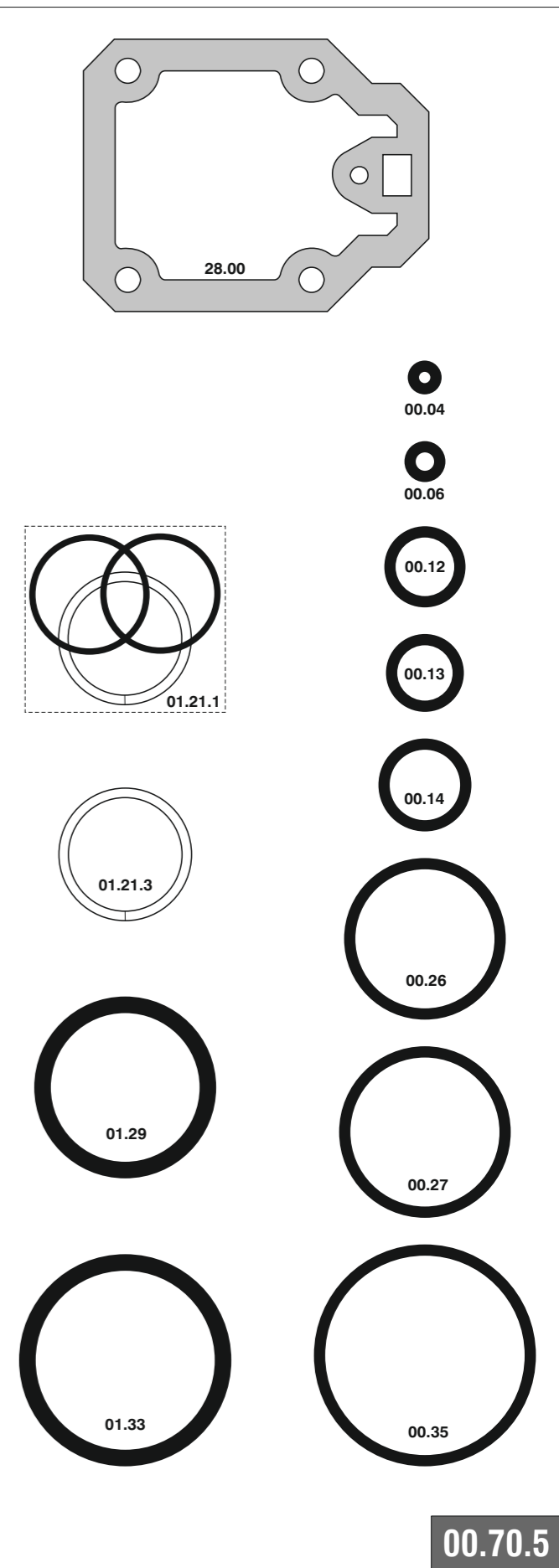

Indice di modifica  
Upgrade number

**5**

**50.16 CLT-3**

cod. 11567540-3