

Azionamento singolo
 Single actuation

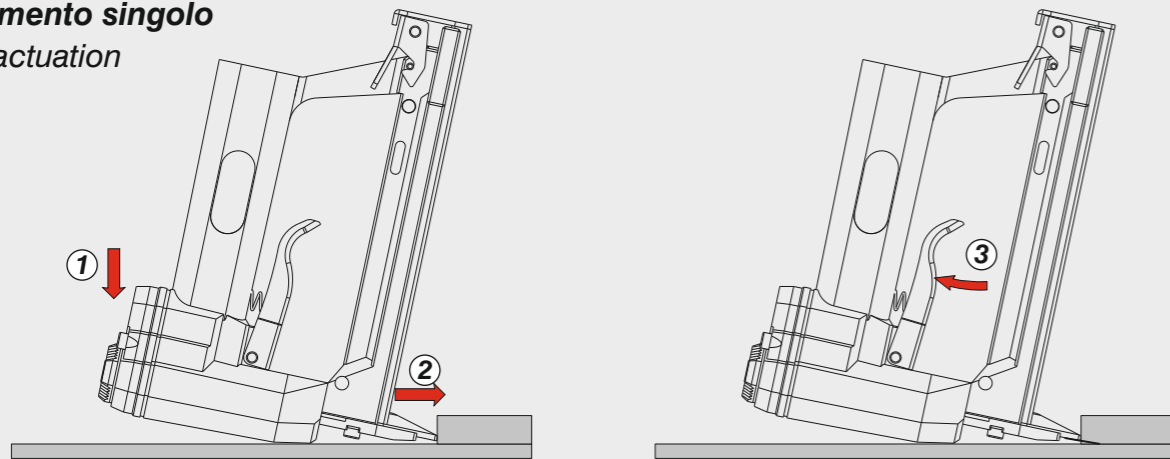

Disincerramento - Jam clearing - Staubeseitigung - Décoincement - Desatascamiento - Απεμπλοκή
 Desencravamento - Deblokkering bij vastlopen - Sıkışma giderme - Rensning av igensättningar - Uvolnění - Uvolnenie

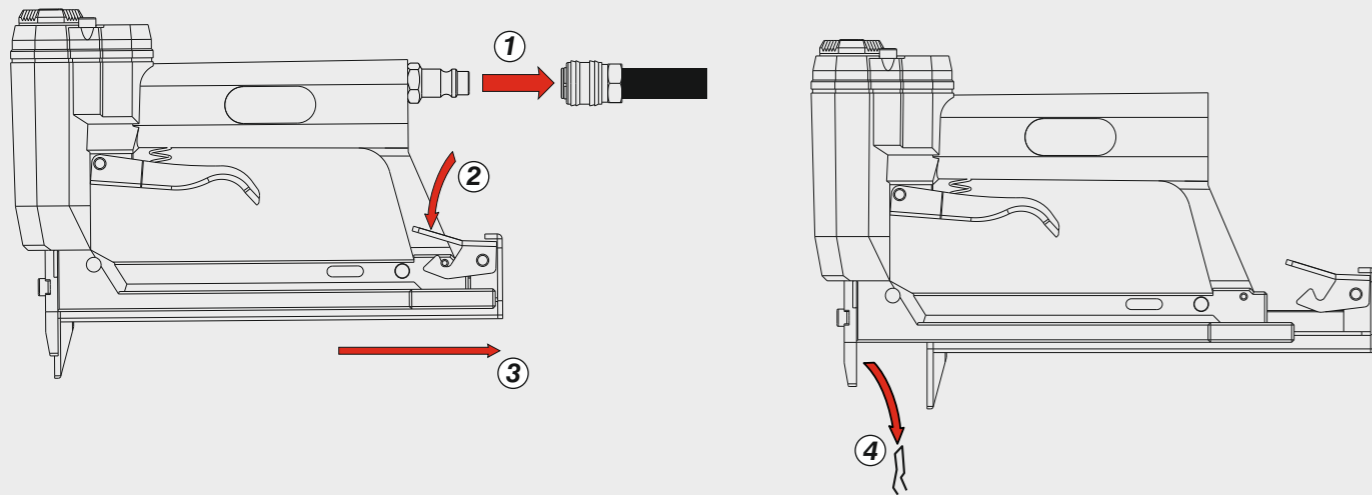

Caricamento - Loading - Laden - Chargement - Carga - Γέμισμα - Carregamento - Laden - Yükleme - Laddning - Plnění - Plnenie

Caricamento posteriore
 Bottom load magazine

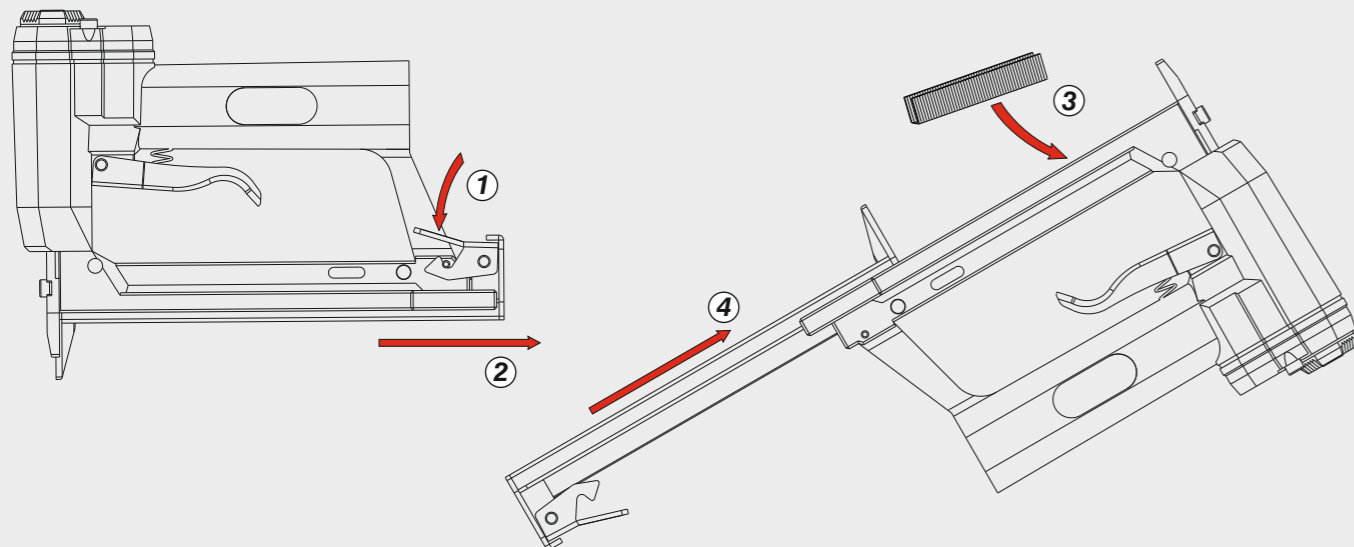

| | |
|---|-----------------|
| Manuale d'uso, manutenzione e parti di ricambio | Parte 2 |
| Manual for use, maintenance and spare parts | Part 2 |
| Bedienungs- und Wartungshandbuch sowie Ersatzteilliste | Teil 2 |
| Mode d'emploi, de maintenance et pièces de rechange | Partie 2 |
| Manual de uso, mantenimiento y recambios | Part 2 |
| Εγχειρίδιο χρήσης, συντήρησης και ανταλλακτικών | Μέρος 2 |
| Manual de uso, manutenção e peças sobresselentes | Parte 2 |
| Handleiding voor gebruik, onderhoud en wisselstukken | Deel 2 |
| Kullanım, bakım ve yedek parça kılavuzu | Kisim 2 |
| Användar-, underhålls- och reservdelshandbok | Del 2 |
| Návod k používání a údržbě a náhradní díly | Část 2 |
| Návod na obsluhu, údržbu a náhradné diely | Časť 2 |



53.5 AB

cod. 10980560



| Dati tecnici Technical data Technische Daten Tehniska data | Caractéristiques techniques Datos técnicos Τεχνικά χαρακτηριστικά Technické údaje | Dados técnicos Technische gegevens Teknik veriler Technické údaje | | |
|---|--|--|--|--|
| Misure impiegabili Lengths Verwendbare Nagellänge Dimensioner som kan användas | Dimensions utiles Medidas de longitud Μήκος Αναλωσίμου Příпустné rozměry | Medidas utilizáveis Toepasbare afmetingen Boy Použitelné rozmery | mm inch | 15 5/8" |
| Capacità caricatore n° punti Magazine capacity Magazinkapazität Magasinkapacitet Antal punkter | Capacité chargeur n° de points Capacidad cargador n° puntos Δυνατότητα γεμιστερά Kapacita zásobníku p. sponek | Capacidade carregador n° pontos Capaciteit magazijn in aantal spijkers Dergi kapasitesi Kapacita zásobníka p. spôn | | 225 |
| Pressione d'esercizio Operating pressure Betriebsdruck Driftryck | Pression d'exercice Presión de servicio Πίεση λειτουργίας Pracovní tlak | Pressão de serviço Werkdruk Çalışma basıncı Prévádzkový tlak | bar psi | 4+6 60+90 |
| Consumo aria Air consumption Luftverbrauch Luftförbrukning | Consommation d'air Consumo aire Κατανάλωση αέρα Spotřeba vzduchu | Consumo ar Luchtverbruik Hava tüketimi Spotřeba vzduchu | lt/colpo ft³/cycle | 0,10 0,00353 |
| Peso Weight Gewicht Vikt | Poids Peso Βάρος Hmotnost | Peso Gewicht Ağırlık Hmotnost | kg lbs | 0,65 1,43 |
| Dimensioni Dimensions Abmessungen Dimensioner (AxBxH) | Dimensions Dimensiones Διαστάσεις Rozměry | Dimensões Afmetingen Boyutlar Rozměry | mm inch | 200x40x145 7-7/8"x1-9/16"x5-23/32" (LxWxH) |
| EN 12549 :2009 EN ISO 4871 :2009 Pressione sonora in pos. operatore Sound pressure in operator's position Schalldruck am Arbeitsplatz Ljudtryck på operatörsplatsen | Pression sonore poste Opérateur Presión sonora en la pos. del operador Ηχητική πίεση στη θέση του χειριστή Akustický tlak v místě obsluhy | Pressão sonora na posição Operador Geluidsdruk op de werkplaats Οπερατόρ ποζιسیونδα ses basıncı Akustický tlak v mieste obsluhy | dB(A) | 76 (K= 4 dB) |
| EN 12549 :2009 EN ISO 3746 :2011 EN ISO 4871 :2009 Potenza sonora emessa Sound power emitted Emitierte Schalleistung Avgiven ljudeffekt | Puissance sonore émise Potencia sonora emitida Εκπεμπόμενη ηχητική ισχύς Emitovaný akustický tlak | Potência sonora emitida Geëmitteerd geluidsvermogen Çıkan ses gücü (ses desibel) Výstupný akustický výkon | dB(A) | 83 (K= 4 dB) |
| CEN ISO/TS 8662-11 :2006 EN ISO 5349-2 :2004 EN 12096 :1999 Emissione vibratoria sull'impugnatura Vibratory emissions on handle Vibrationsemission am Griff Vibrationsemission på handtaget | Émission vibratoire sur la prise en main Emisión de vibraciones en la empuñadura Εκπεμπόμενες δονήσεις στη λαβή Emise vibrací na rukojet | Emissão vibratória na empunhadura Trillingsemissie op de handgreep Tutamak üzerinde vibrasyon emisyonları Emisie vibrácií na rukoväti | m/s² | <2,5 (K= 2 m/s ²) |

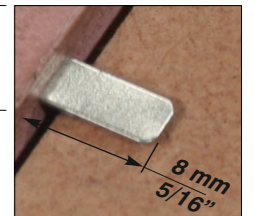

Tipo di punto
Type of fastener
Befestigungsmittel
Type de rivet
Tipo de punto
Τύπος αναλωσίμου
Tipo de agrafó
Type nietjes
Zimba ve çivi tipleri
Typ av stygn
Typ sponky
Typ spony

53

Spessore 0.5

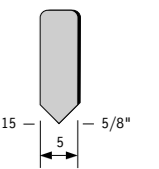

Width: .185" (3/16")
 Length: .59"
 Thickness: .0197"

10980560_535AB_9_rev22_12/01/2026_MH

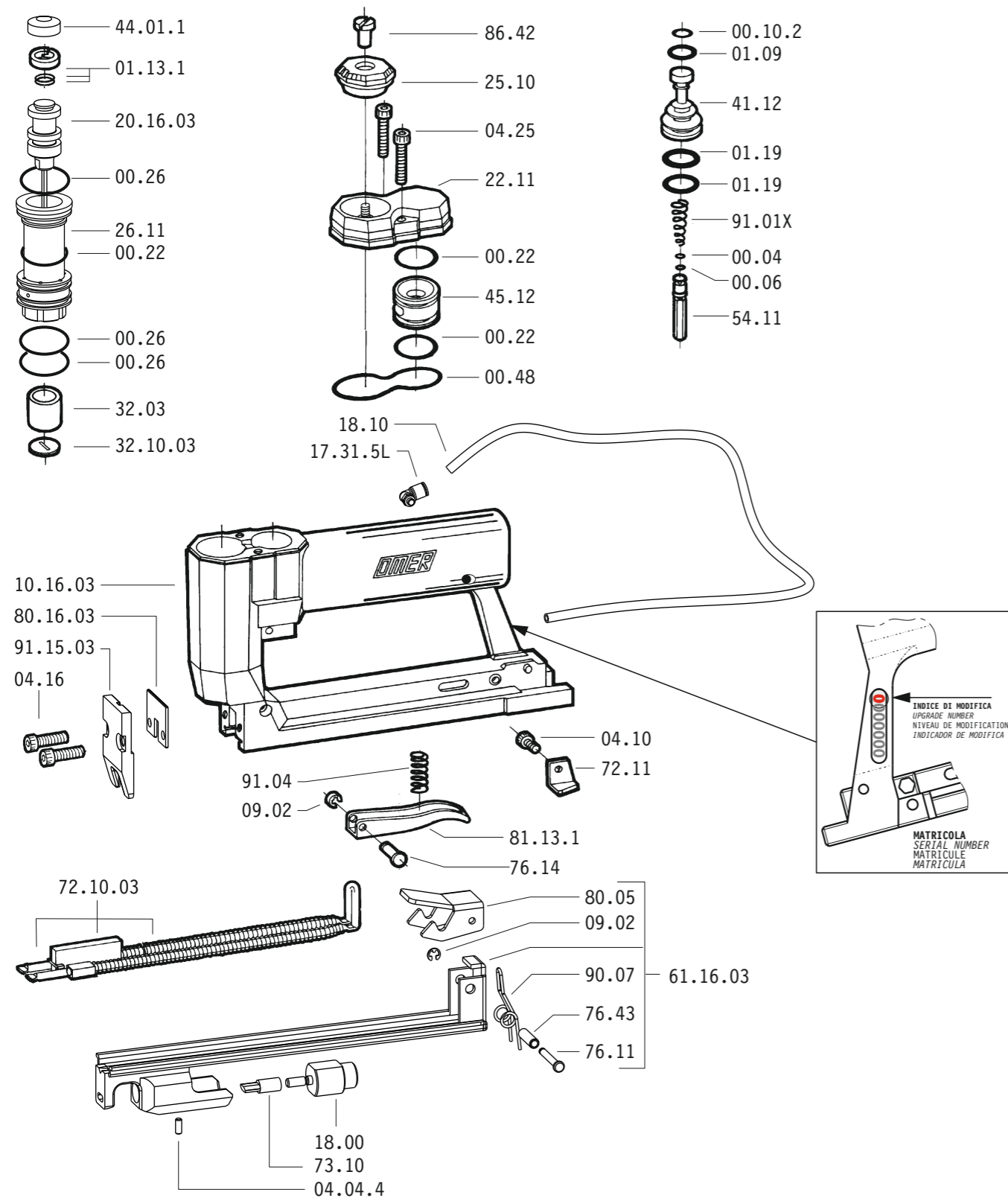

Dotazioni - Equipment - Ausstattung - Outillage - Dotaciones - Εξοπλισμός
Dotações - Uitrusting - Donanımlar - Utrustning - Vybavení - Vybava

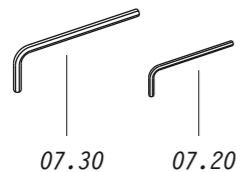

53.5 AB

cod. 10980560

| Cod. | Descrizione | Description |
|----------|---------------------|--------------------|
| 00.04 | O-Ring | O-Ring |
| 00.06 | O-Ring | O-Ring |
| 00.10.2 | O-Ring | O-Ring |
| 00.22 | O-Ring | O-Ring |
| 00.26 | O-Ring | O-Ring |
| 00.48 | O-Ring | O-Ring |
| 01.09 | O-Ring | O-Ring |
| 01.13.1 | Guarnizione | Gasket |
| 01.19 | O-Ring | O-Ring |
| 04.04.4 | Vite | Screw |
| 04.10 | Vite | Screw |
| 04.16 | Vite | Screw |
| 04.25 | Vite | Screw |
| 07.20 | Chiave esagonale | Hex. Bar wrench |
| 07.30 | Chiave esagonale | Hex. Bar wrench |
| 09.02 | Anello elastico | Elastic ring |
| 17.31.5 | Attacco | Coonection |
| 18.00 | Cilindro Pneumatico | Pneumatic Cylinder |
| 18.10 | Tubo | Pipe |
| 22.11 | Testa | Head |
| 25.10 | Deflettore | Exhaust deflector |
| 26.11 | Cilindro | Cylinder |
| 32.03 | Ammortizzatore | Bumper |
| 41.12 | Pistone valvola | Valve |
| 44.01.1 | Ammortizzatore | Bumper |
| 45.12 | Anello valvola | Ring |
| 54.11 | Pulsante | Trigger valve |
| 72.11 | Fermo carrello | Slider stop |
| 73.10 | Piegatore | Bender |
| 76.11 | Perno | Pin |
| 76.14 | Perno | Pin |
| 76.43 | Perno | Pin |
| 80.05 | Grilletto chiusura | Trigger |
| 81.13.1 | Grilletto comando | Trigger |
| 86.42 | Vite deflettore | Deflector screw |
| 90.07 | Molla | Spring |
| 91.01X | Molla | Spring |
| 91.04 | Molla | Spring |
| 10.16.03 | Corpo | Body |
| 20.16.03 | Battente | Driver |
| 32.10.03 | Rondella | Washer |
| 61.16.03 | Carrello | Slider |
| 72.10.03 | Spingipunto | Pusher |
| 80.16.03 | Controtestina | Nose |
| 91.15.03 | Testina | Nose plate |

Guarnizioni - O-Rings - Dichtungen - Juntas - Δακτύλιος στεγανοποίησης
Vedantes - O-rings - Contalar - O-ringar - Těsnění - Tesnenia

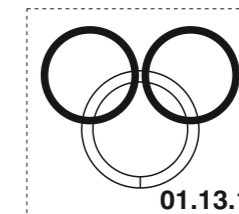

00.04

00.06

00.10.2

01.09

00.14

01.19

00.22

00.26

00.48

00.71.1

53.5 AB

cod. 10980560

Indice di modifica
Upgrade number

9