

SX.438 CL3-3 STAPLES SX (18GA)
Crown: .232" 15 - 5/8"
USE GENUINE OMER FASTENERS Crown: 0,90x1,25 40 - 1-9/16"
P_{s max}: 7,5 bar (105 PSI)

3ETSX438CL3-3

omer s.p.a. CE UK CA
Via Foresto, 42 - 31058 SUSEGANA (TV) ITALY

3ETCE

WARNING
1. Read and understand tool labels and manual.
2. Failure to follow warnings could result in DEATH or SERIOUS INJURY.
3. Operators and others in the work area MUST wear safety glasses with side shields.
4. Keep fingers AWAY from the trigger when not driving fasteners to avoid accidental firing.
5. Choice of trigger systems is important. Check manual for triggering options.
6. NEVER point tool at your self or others in work area.
7. NEVER use oxygen or other bottled gasses. Explosion may occur.

3ET99

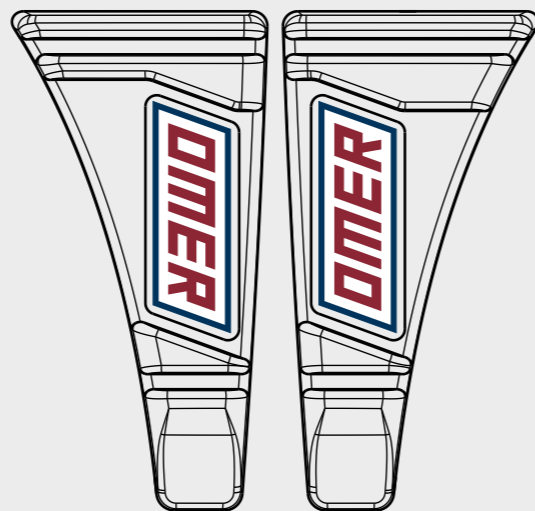

2007042L

2007042R

Schema di collegamento - Connecting diagram

Valvola 3/2 NC
Valve 3/2 NC

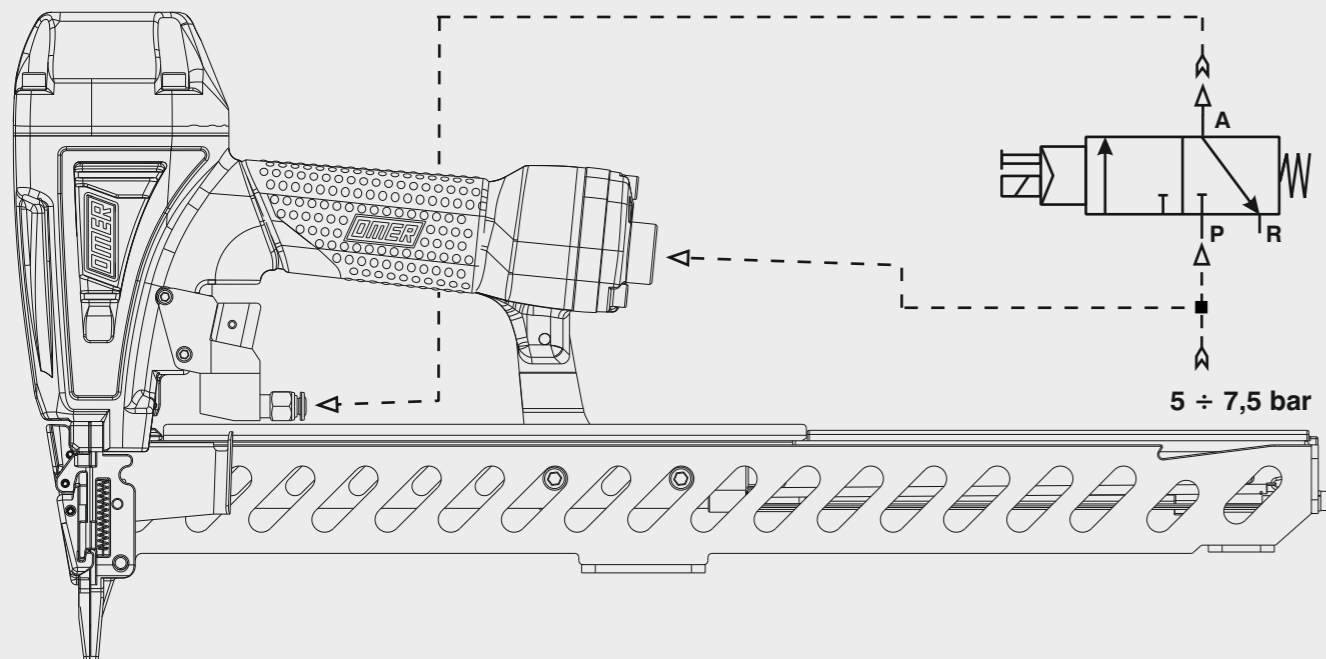

Manuale d'uso, manutenzione e parti di ricambio
Manual for use, maintenance and spare parts
Bedienungs- und Wartungshandbuch sowie Ersatzteilleiste
Mode d'emploi, de maintenance et pièces de rechange
Manual de uso, mantenimiento y recambios
Εγχειρίδιο χρήσης, συντήρησης και ανταλλακτικών
Manual de uso, manutenção e peças sobresselentes
Handleiding voor gebruik, onderhoud en wisselstukken
Kullanım, bakım ve yedek parça kılavuzu
Användar-, underhålls- och reservdelshandbok
Návod k používání a údržbě a náhradní díly
Návod na obsluhu, údržbu a náhradné diely

Parte 2
Part 2
Teil 2
Partie 2
Part 2
Μέρος 2
Parte 2
Deel 2
Kisim 2
Del 2
Část 2
Čast 2



SX.438 CL3-3

cod. 14470B4530-3



Dati tecnici

Technical data
Technische Daten
Tehniska data

Caractéristiques techniques

Datos técnicos
Τεχνικά χαρακτηριστικά
Technické údaje

Dados técnicos

Technische gegevens
Teknik veriler
Technické údaje

Misure impiegabili Lengths Verwendbare Nagellänge Dimensioner som kan användas	Dimensions utiles Medidas de longitud Μήκος Αναλωσίμου Přípustné rozměry	Medidas utilizáveis Toepasbare afmetingen Boy Použitelné rozmery	mm inch	15+40 5/8" ÷ 1-9/16"
Capacità caricatore n° punti Magazine capacity Magazinkapazität Nägel Magasinkapacitet Antal punkter	Capacité chargeur n° de points Capacidad cargador n° puntos Δυνατότητα γεμιστέρα Kapacita zásobníku p. sponek	Capacidade carregador n° pontos Capaciteit magazijn in aantal spijkers Dergi kapasitesi Kapacita zásobníku p. spôn		300
Pressione d'esercizio Operating pressure Betriebsdruck Drifttryck	Pression d'exercice Presión de servicio Πίεση λειτουργίας Pracovní tlak	Pressão de serviço Werkdruk Çalışma basıncı Prevádzkový tlak	bar psi	5 ÷ 7,5 70 ÷ 105
Consumo aria Air consumption Luftverbrauch Luftförbrukning	Consommation d'air Consumo aire Κατανάλωση αέρα Spotřeba vzduchu	Consumo ar Luchtverbruik Hava tüketimi Spotřeba vzduchu	lt/colpo ft³/cycle	0,50 0,0176
Peso Weight Gewicht Vikt	Poids Peso Βάρος Hmotnost	Peso Gewicht Ağırlık Hmotnost	kg lbs	1,90 4,19
Dimensioni Dimensions Abmessungen Dimensioner (AxBxH)	Dimensions Dimensiones Διαστάσεις Rozměry	Dimensões Afmetingen Boyutlar Rozmery	mm inch	480x64x247 18-7/8"x2-1/2"x9-3/4" (LxWxH)
EN 12549 :2009 EN ISO 3746 :2011 EN ISO 4871 :2009 Potenza sonora emessa Sound power emitted Emitierte Schalleistung Avgiven ljudeffekt	Puissance sonore émise Potencia sonora emitida Εκτεμπόμενη ηχητική ισχύς Emitovaný akustický tlak	Potência sonora emitida Geëmitteerd geluidsvermogen Çıkan ses gücü (ses desibel) Výstupný akustický výkon	dB(A)	94 (K = 4 dB)

Tipo di punto
Type of fastener
Befestigungsmittel
Type de rivet
Τύπος αναλωσίμου
Tipo de agrafio
Type nietjes
Zimba ve çivi tipleri
Typ av stýgn
Typ sponky
Typ spony

SX

0,90x1,25

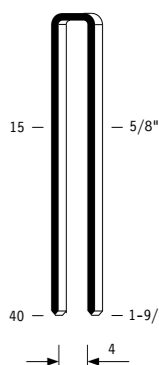

Crown: .232" (1/4")
Gauge: 18

14470B4530-3_SC438CL3-3_4_rev22_17/10/2025 MH

**DO NOT
HANDHELD
THIS TOOL**



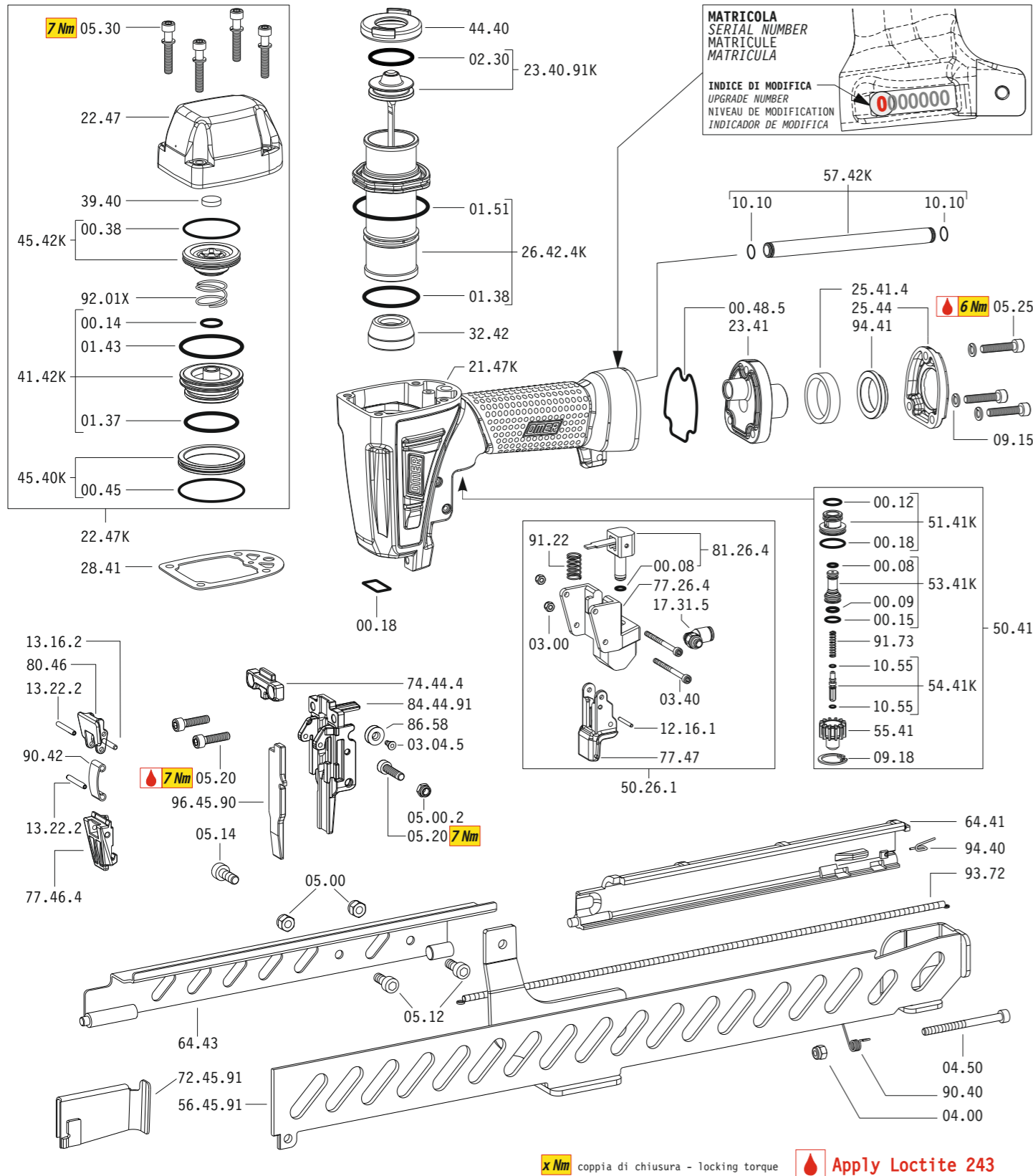

Dotazioni - Equipment - Ausstattung - Outillage - Dotaciones - Εξοπλισμός
Dotações - Uitrusting - Donanımlar - Utrustning - Vybavení - Vybava

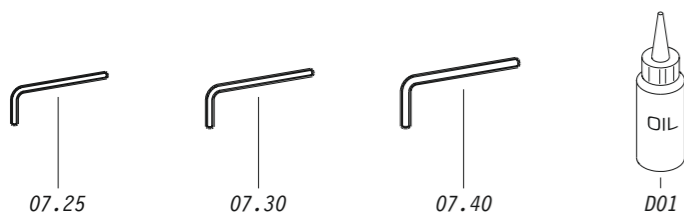

SX.438 CL3-3

cod. 14470B4530-3

Cod.	Descrizione	Description
00.08	O-Ring	O-Ring
00.09	O-Ring	O-Ring
00.12	O-Ring	O-Ring
00.14	O-Ring	O-Ring
00.15	O-Ring	O-Ring
00.18	O-Ring	O-Ring
00.38	O-Ring	O-Ring
00.45	O-Ring	O-Ring
00.48.5	Guarnizione	Gasket
01.37	O-Ring	O-Ring
01.38	O-Ring	O-Ring
01.43	O-Ring	O-Ring
01.51	O-Ring	O-Ring
02.30	O-Ring	O-Ring
03.00	Dado	Nut
03.04.5	Vite	Screw
03.40	Vite	Screw
04.00	Dado	Nut
04.50	Vite	Screw
05.00	Dado	Nut
05.00.2	Dado	Nut
05.12	Vite	Screw
05.14	Vite	Screw
05.20	Vite	Screw
05.25	Vite	Screw
05.30	Vite	Screw
07.25	Chiave esagonale	Hex. bar wrench
07.30	Chiave esagonale	Hex. bar wrench
07.40	Chiave esagonale	Hex. bar wrench
09.15	Rondella	Washer
09.18	Anello elastico	Elastic ring
10.10	O-Ring	O-Ring
10.55	O-Ring	O-Ring
12.16.1	Spina	Pin
13.16.2	Spina	Pin
13.22.2	Spina	Pin
17.31.5	Raccordo	Air plug
21.47K	Corpo	Body
22.47K	Testa completa	Head unit
22.47	Testa	Head
23.41	Fondello	Case back
25.41.4	Silenziatore	Silencer
25.44	Deflettore	Exhaust deflector
26.42.4K	Cilindro	Cylinder
28.41	Guarnizione	Gasket
32.42	Ammortizzatore	Bumper
39.40	Guarnizione	Gasket
41.42K	Valvola	Valve
44.40	Guarnizione	Gasket
45.40K	Anello valvola	Ring
45.42K	Anello testa	Ring
50.26.1	Comando a distanza	Remote control
50.41	Pulsante completo	Trigger valve assy
51.41K	Boccola	Valve housing
53.41K	Pistone servovalvola	Valve piston
54.41K	Pulsante	Trigger valve
55.41	Raccordo pulsante	Bush
57.42K	Tubo di scarico	Exhaust pipe
64.41	Carter	Hold down
64.43	Carter	Hold down
74.44.4	Staffa testina	Head bracket
77.26.4	Supporto	Support
77.46.4	Guida testina	Head guide
77.47	Guida sicura	Safety guide
80.46	Grilletto testina	Trigger
81.26.4	Pistoncino	Piston
86.58	Carrucola	Pulley
90.40	Molla	Spring
90.42	Molla	Spring
91.22	Molla	Spring
91.73	Molla	Spring
92.01X	Molla	Spring
93.72	Molla	Spring
94.40	Molla	Molla
94.41	Boccola	Bushing
23.40.91K	Battente	Driver
56.45.91	Caricatore	Magazine
72.45.91	Spingipunto	Pusher
84.44.91	Controtestina	Nose
96.45.90	Testina	Nose plate
D01	Bocchetta olio	Oiler

Guarnizioni - O-Rings - Dichtungen - Juntas - Δακτύλιος στεγανοποίησης - Vedantes - O-ringen - Contalar - O-ringar - Tésnéni - Tesnenia

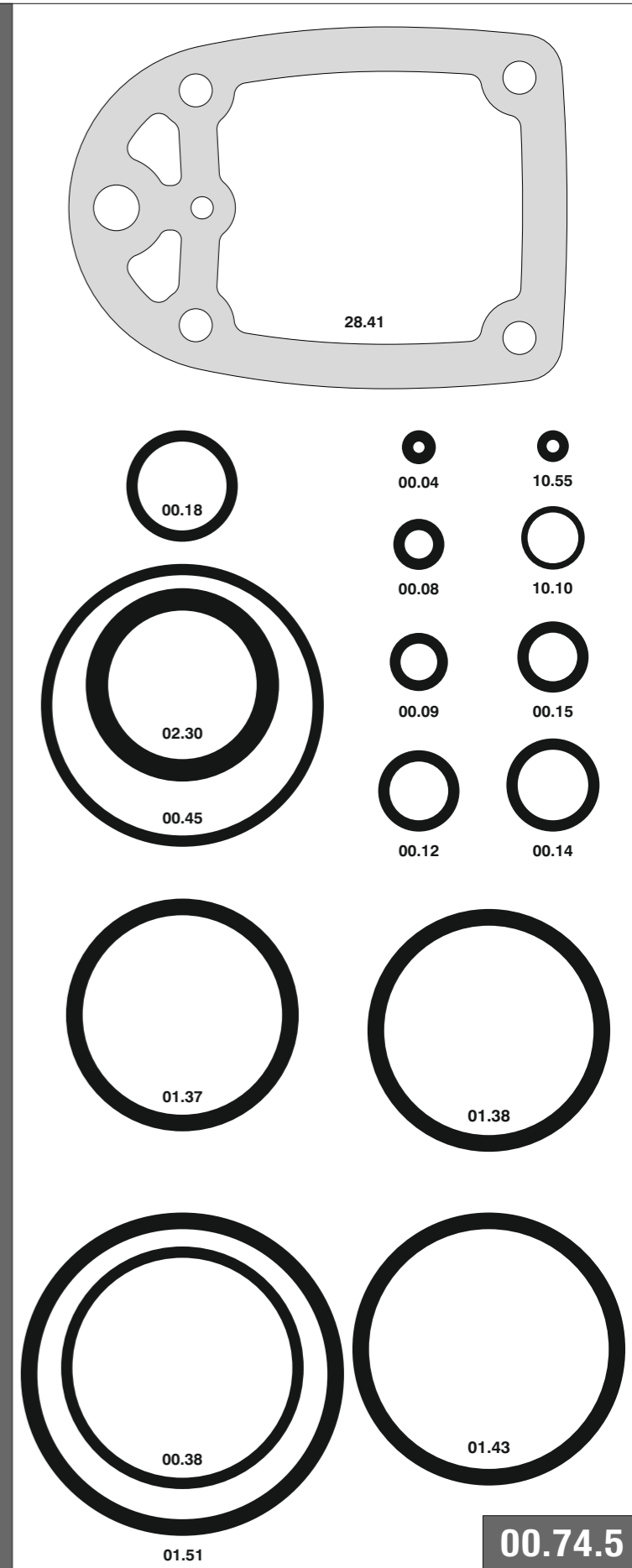

SX.438 CL3-3

cod. 14470B4530-3

Indice di modifica
Upgrade number

4

Caricamento da sopra
Top load magazine

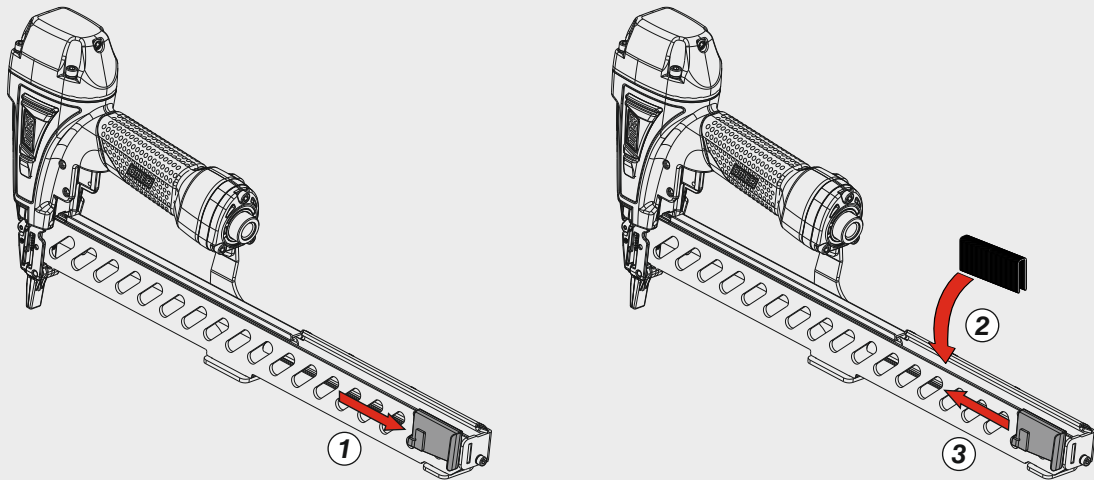

Disinceppamento - Jam clearing - Staubeseitigung - Décoincement - Desatascamiento - Απεμπλοκή
Desencravamento - Deblokkering bij vastlopen - Sıkışma giderme - Rensning av igensättningar - Uvoľnění - Uvoľnenie

