

**92.438 CL3-11** STAPLES 92 (18GA)

USE GENUINE OMER FASTENERS Crown: .334" 15 - 5/8"  
P<sub>s max</sub>: 7,5 bar (105 PSI) 1,00x1,25 40 - 1-9/16"

3ET92438CL311

**omer** s.p.a. CE UK CA  
Via Foresto, 42 - 31058 SUSEGANA (TV) ITALY

3ETCE

**WARNING**  
1. Read and understand tool labels and manual.  
Failure to follow warnings could result in DEATH or SERIOUS INJURY.  
2. Operators and others in the work area MUST wear safety glasses with side shields.  
3. Keep fingers AWAY from the trigger when not driving fasteners to avoid accidental firing.  
4. Choice of trigger systems is important. Check manual for triggering options.  
5. NEVER point tool at your self or others in work area.  
6. NEVER use oxygen or other bottled gasses. Explosion may occur.

3ET99

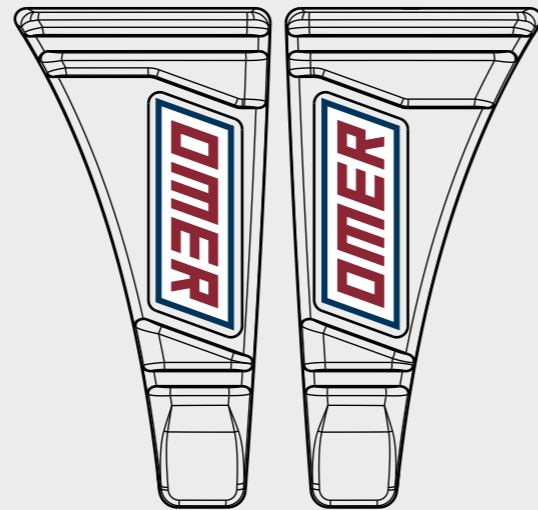

2007042L

2007042R

Schema di collegamento - Connecting diagram

Valvola 3/2 NA  
Valve 3/2 NA

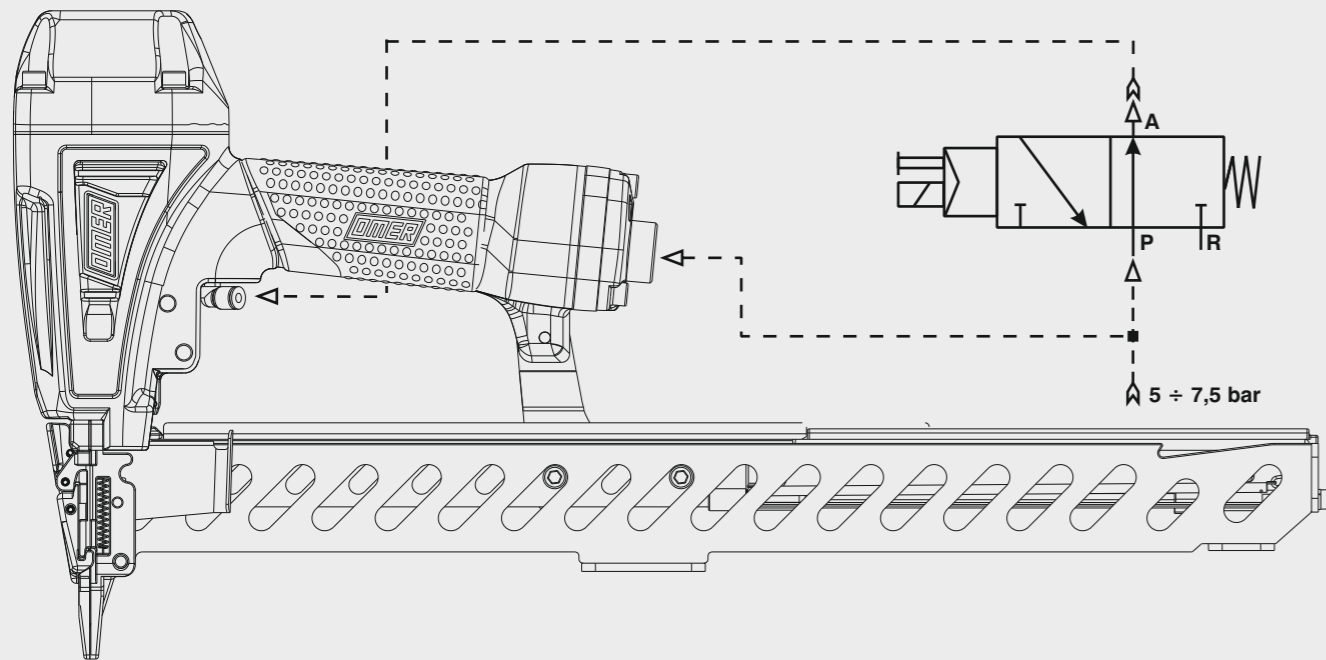

Manuale d'uso, manutenzione e parti di ricambio  
Manual for use, maintenance and spare parts  
Bedienungs- und Wartungshandbuch sowie Ersatzteilleiste  
Mode d'emploi, de maintenance et pièces de rechange  
Manual de uso, mantenimiento y recambios  
Εγχειρίδιο χρήσης, συντήρησης και ανταλλακτικών  
Manual de uso, manutenção e peças sobresselentes  
Handleiding voor gebruik, onderhoud en wisselstukken  
Kullanım, bakım ve yedek parça kılavuzu  
Användar-, underhålls- och reservdelshandbok  
Návod k používání a údržbě a náhradní díly  
Návod na obsluhu, údržbu a náhradné diely

Parte 2  
Part 2  
Teil 2  
Partie 2  
Part 2  
Μέρος 2  
Parte 2  
Deel 2  
Kisim 2  
Del 2  
Část 2  
Čast 2



**92.438 CL3-11**

cod. 144724530-11



Dati tecnici

Technical data  
Technische Daten  
Tehniska data

Caractéristiques techniques

Datos técnicos  
Τεχνικά χαρακτηριστικά  
Technické údaje

Dados técnicos

Technische gegevens  
Teknik veriler  
Technické údaje

<b>Misure impiegabili</b> Lengths Verwendbare Nagellänge Dimensioner som kan användas	Dimensions utiles Medidas de longitud Μήκος Αναλωσίμου Přípustné rozměry	Medidas utilizáveis Toepasbare afmetingen Boy Použitelné rozmery	<b>mm</b> <b>inch</b>	<b>15+40</b> <b>5/8" ± 1-9/16"</b>
<b>Capacità caricatore n° punti</b> Magazine capacity Magazinkapazität Nägel Magasinkapacitet Antal punkter	Capacité chargeur n° de points Capacidad cargador n° puntos Δυνατότητα γεμιστερα Kapacita zásobníku p. sponek	Capacidade carregador n° pontos Capaciteit magazijn in aantal spijkers Dergi kapasitesi Kapacita zásobníka p. spôn		<b>300</b>
<b>Pressione d'esercizio</b> Operating pressure Betriebsdruck Drifttryck	Pression d'exercice Presión de servicio Πίεση λειτουργίας Pracovní tlak	Pressão de serviço Werkdruk Çalışma basıncı Prevádzkový tlak	<b>bar</b> <b>psi</b>	<b>5 ± 7,5</b> <b>70 ± 105</b>
<b>Consumo aria</b> Air consumption Luftverbrauch Luftförbrukning	Consommation d'air Consumo aire Κατανάλωση αέρα Spotreba vzduchu	Consumo ar Luchtverbruik Hava tüketimi Spotreba vzduchu	<b>lt/colpo</b> <b>ft<sup>3</sup>/cycle</b>	<b>0,50</b> <b>0,0176</b>
<b>Peso</b> Weight Gewicht Vikt	Poids Peso Βάρος Hmotnost	Peso Gewicht Ağırlık Hmotnost	<b>kg</b> <b>lbs</b>	<b>1,95</b> <b>4,30</b>
<b>Dimensioni</b> Dimensions Abmessungen Dimensioner (AxBxH)	Dimensions Dimensiones Διαστάσεις Rozměry	Dimensões Afmetingen Boyutlar Rozmery	<b>mm</b> <b>inch</b>	<b>480x64x247</b> <b>18-7/8"x2-1/2"x9-3/4"</b> <b>(LxWxH)</b>
<b>EN 12549 :2009</b> <b>EN ISO 3746 :2011</b> <b>EN ISO 4871 :2009</b> <b>Potenza sonora emessa</b> Sound power emitted Emitierte Schalleistung Avgiven ljudeffekt	Puissance sonore émise Potencia sonora emitida Εκτεμπόμενη ηχητική ισχύς Emitovaný akustický tlak	Potência sonora emitida Geëmitteerd geluidsvermogen Çıkan ses gücü (ses desibeli) Výstupný akustický výkon	<b>dB(A)</b>	<b>94</b> <b>(K = 4 dB)</b>

**Tipo di punto**  
Type of fastener  
Befestigungsmittel  
Type de rivet  
Τύπος αναλωσίμου  
Tipo de agrafio  
Type nietjes  
Zimba ve çivi tipleri  
Typ av stygn  
Typ sponky  
Typ sponky

**92**

1,00x1,25

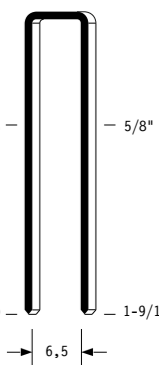

Crown: .334" (5/16")  
Gauge: 18

144724530-11\_92438CL3-11\_4\_rev22\_24/10/2025\_MH



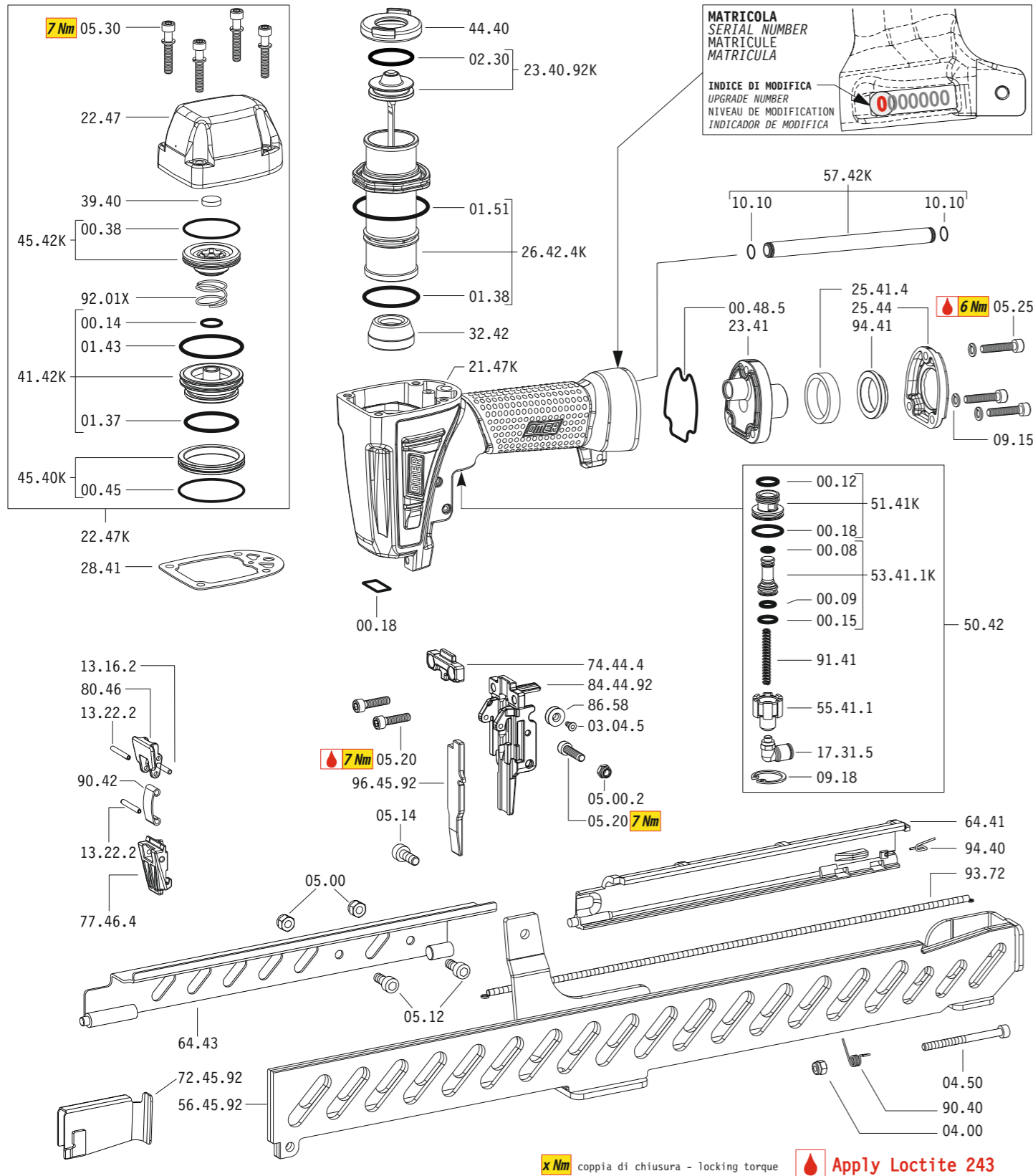

Dotazioni - Equipment - Ausstattung - Outillage - Dotaciones - Εξοπλισμός  
Dotações - Uitrusting - Donanımlar - Utrustning - Vybavení - Vybava

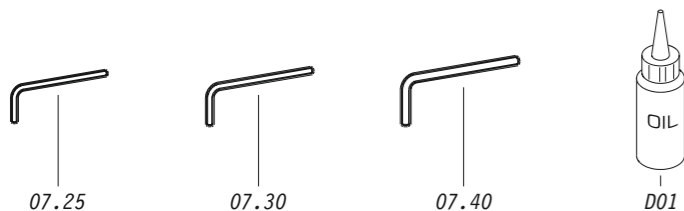

**92.438 CL3-11**

cod. 144724530-11

Cod.	Descrizione	Description
00.08	O-Ring	O-Ring
00.09	O-Ring	O-Ring
00.12	O-Ring	O-Ring
00.14	O-Ring	O-Ring
00.15	O-Ring	O-Ring
00.18	O-Ring	O-Ring
00.38	O-Ring	O-Ring
00.45	O-Ring	O-Ring
00.48.5	Guarnizione	Gasket
01.37	O-Ring	O-Ring
01.38	O-Ring	O-Ring
01.43	O-Ring	O-Ring
01.51	O-Ring	O-Ring
02.30	O-Ring	O-Ring
03.04.5	Vite	Screw
04.00	Dado	Nut
04.50	Vite	Screw
05.00	Dado	Nut
05.00.2	Dado	Nut
05.12	Vite	Screw
05.14	Vite	Screw
05.20	Vite	Screw
05.25	Vite	Screw
05.30	Vite	Screw
07.25	Chiave esagonale	Hex. bar wrench
07.30	Chiave esagonale	Hex. bar wrench
07.40	Chiave esagonale	Hex. bar wrench
09.15	Rondella	Washer
09.18	Anello elastico	Elastic ring
10.10	O-Ring	O-Ring
13.16.2	Spina	Pin
13.22.2	Spina	Pin
17.31.5	Raccordo	Air plug
21.47K	Corpo	Body
22.47K	Testa completa	Head unit
22.47	Testa	Head
23.41	Fondello	Case back
25.41.4	Silenziatore	Silencer
25.44	Deflettore	Exhaust deflector
26.42.4K	Cilindro	Cylinder
28.41	Guarnizione	Gasket
32.42	Ammortizzatore	Bumper
39.40	Guarnizione	Gasket
41.42K	Valvola	Valve
44.40	Guarnizione	Gasket
45.40K	Anello valvola	Ring
45.42K	Anello testa	Ring
50.42	Pulsante completo	Trigger valve assy
51.41K	Boccola	Valve housing
53.41.1K	Pistone servovalvola	Valve piston
55.41.1	Raccordo pulsante	Bush
57.42K	Tubo di scarico	Exhaust pipe
64.41	Carter	Hold down
64.43	Carter	Hold down
74.44.4	Staffa testina	Head bracket
77.46.4	Guida testina	Head guide
80.46	Grilletto testina	Trigger
86.58	Carrucola	Pulley
90.40	Molla	Spring
90.42	Molla	Spring
91.41	Molla	Spring
92.01X	Molla	Spring
93.72	Molla	Spring
94.40	Molla	Molla
94.41	Boccola	Bushing
23.40.92K	Battente	Driver
56.45.92	Caricatore	Magazine
72.45.92	Spingipunto	Pusher
84.44.92	Controtestina	Nose
96.45.92	Testina	Nose plate
D01	Bocchetta olio	Oiler

Guarnizioni - O-Rings - Dichtungen - Juntas - Δακτύλιος στεγανοποίησης - Vedantes - O-ringen - Contalar - O-ringar - Tésnéni - Tesnenia

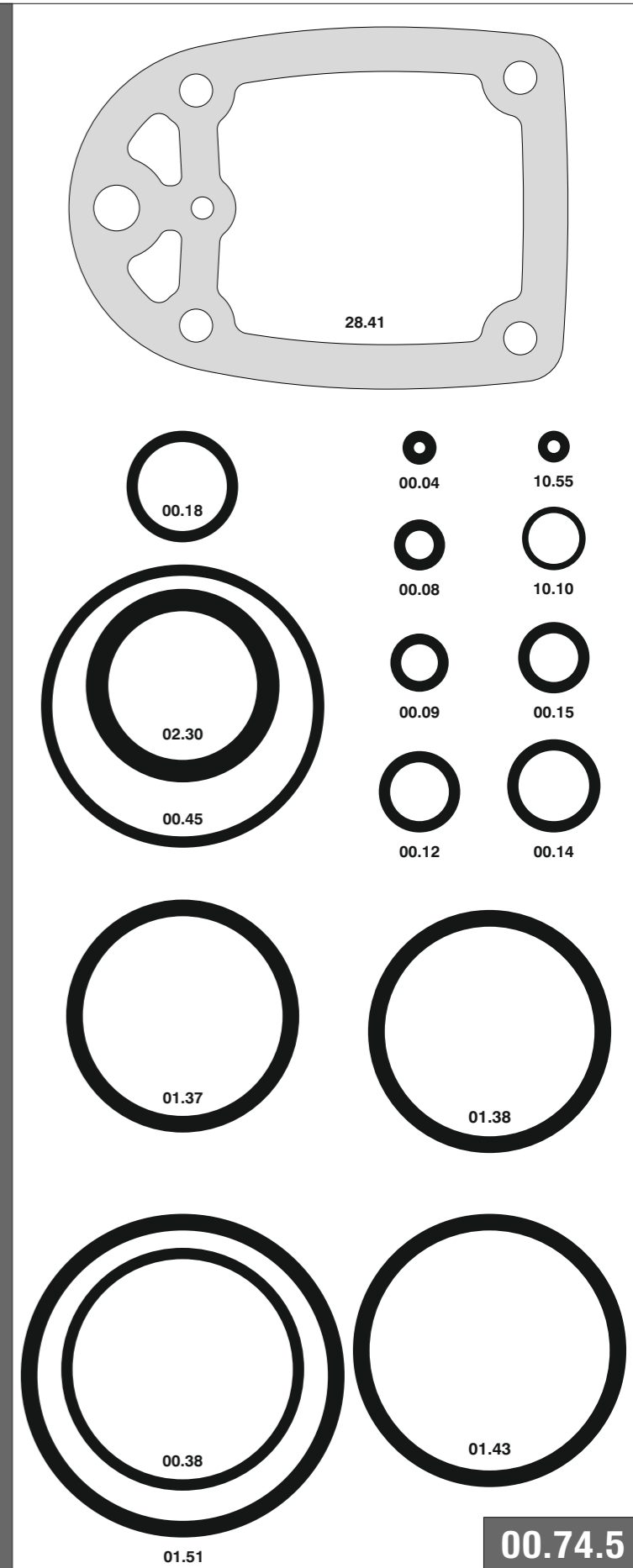

**92.438 CL3-11**

cod. 144724530-11

Indice di modifica  
Upgrade number

**4**

**Caricamento da sopra**  
Top load magazine

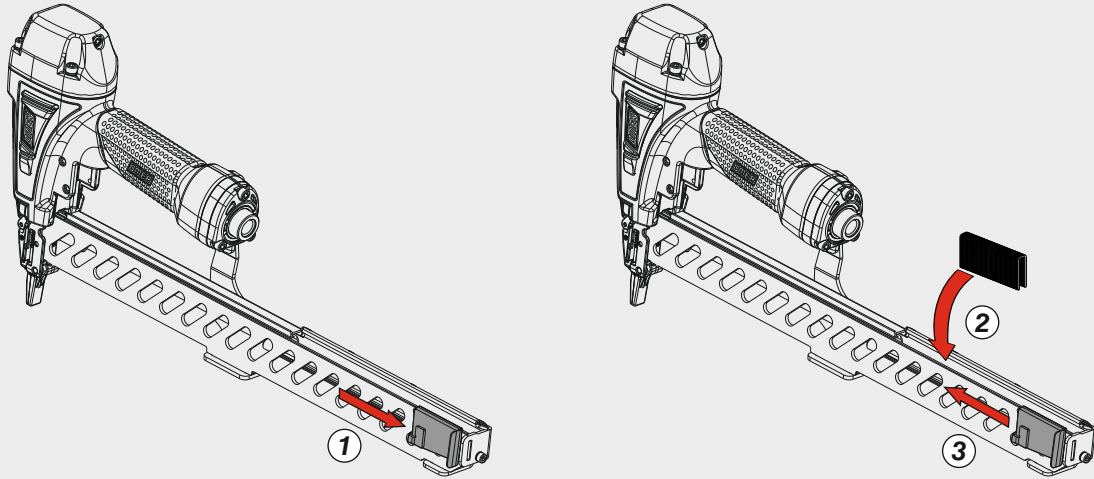

**Disinceppamento - Jam clearing - Staubeseitigung - Décoincement - Desatascamiento - Απεμπλοκή**  
**Desencravamento - Deblokkering bij vastlopen - Sıkışma giderme - Rensning av igensättningar - Uvoľnění - Uvoľnenie**

